

11 kVA Bidirectional Power Unit, 4-phases



OVERVIEW

BMPU-R2 is a grid-tied power supply capable of bidirectional conversion between AC (grid) and DC.

Designed for smart grid (V2G, V2H, V2L) applications, it features a modular design capable of parallel operation, and can be used as a part of a very high-power system.

Its innovative 4-phases design enables operation in three-phase or single-phase operation.

Typical application: electric vehicle supply equipment (EVSE)

VERSIONS

	DC SIDE
BMPU-R2-500-32	500V – 32 A

FEATURES

- 16ARMS per phase
 - 3-Phase without neutral
 - 3-Phase with explicit neutral control
 - Single phase
- Single-phase operation in G2V/V2G up to 32ARMS via AC connector pin reconfiguration
- AC connection to standard 400/480 VAC, 50/60 Hz grid. No neutral required
- Parallel operation in V2L mode supported in three-phase operation up to 22 kW
- Extra power mode up to 12.5kW peak
- Reinforced galvanic isolation between input and output
- Integrated forced air cooling with fan speed control
- Fits a 19" rack, 2U
- CANopen compatible digital bus with advanced control, monitoring, and logging capabilities
- Integrated protections including AC and DC pre-charge switches, OCP, OTP and UVLO
- Certified grid codes: VDE-AR-N 4105

BLOCK DIAGRAM

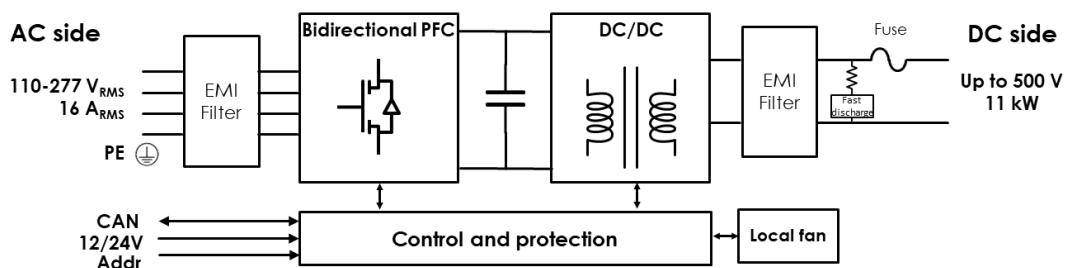

TABLE OF CONTENTS

1.	Changes against previous versions	5
1.1.	V2.1 to V2.3.....	5
1.1.1.	<i>Mechanical</i>	5
1.1.2.	<i>Hardware</i>	7
1.2.	V2.3 to V2.4.....	8
1.3.	V2.4 to V2.5.....	8
1.4.	CAN address logic for SW versions v2.6.2r and above	9
2.	Absolute maximum ratings	9
3.	Electrical Characteristics.....	10
3.1.	Earthing system compatibility	11
3.2.	Safe Operating Area	11
3.3.	Typical efficiency.....	13
3.4.	Output power derating.....	16
3.5.	DC current ripple	17
4.	Safety instructions	18
4.1.	Caution	18
4.2.	Installation.....	18
4.3.	Input rating	18
4.4.	Live circuits.....	18
4.5.	Hot surface.....	18
4.6.	Parts substitution and modifications.....	19
4.7.	Environmental condition	19
4.8.	Normative compliance.....	20
5.	Installation	22
5.1.	Mechanical installation	22
5.1.1.	<i>Handling</i>	22
5.1.2.	<i>Mounting</i>	22
5.2.	Electrical installation.....	23
5.2.1.	<i>Legal installation</i>	23
5.2.2.	<i>Safety Notice</i>	23
5.2.3.	<i>Protective earth</i>	23
5.2.4.	<i>AC input</i>	23
5.2.5.	<i>LV DC input</i>	24
5.2.6.	<i>DC Output</i>	24
5.2.7.	<i>EMI requirements</i>	24
5.2.8.	<i>Series operation</i>	24
5.3.	Disposal.....	25
6.	Hardware specification	26

6.1.	Theory of operation	26
6.2.	Interfaces	27
6.2.1.	<i>Low voltage connector</i>	27
6.2.2.	<i>AC side connector</i>	27
6.2.3.	<i>DC side connectors</i>	28
6.2.4.	<i>COM connector</i>	29
6.2.5.	<i>Emergency Shutdown</i>	30
6.2.6.	<i>Address selector and Charge Permission</i>	30
6.2.7.	<i>Protective Earth</i>	34
7.	Control specifications	35
7.1.	Theory of operation	35
7.2.	User inputs	35
7.2.1.	<i>Nominal operation</i>	35
7.2.2.	<i>Special operation</i>	40
7.3.	User outputs	41
7.4.	CAN communication	43
8.	Mechanical specifications	52
9.	Maintenance	52
9.1.	Cleaning	52
9.2.	Cooling fan	52
9.3.	Fuse replacement	52
10.	Ordering information	53
10.1.	Product Reference	53
10.2.	Product accessories	53
10.3.	Related products	55

Important note: this datasheet contains advanced information about an unreleased product. Values are susceptible to change in significant ways without prior notice

**WARNING**

This equipment operates at voltages and currents that can result in electrical shock, fire hazard and/or personal injury if not properly handled or applied. Equipment must be used with necessary caution and appropriate safeguards employed to avoid personal injury or property damage.

This board must be used only by qualified engineers and technicians familiar with risks associated with handling high voltage electrical and mechanical components, systems, and subsystems.

1. Changes against previous versions

1.1. V2.1 to V2.3

1.1.1. Mechanical

Handles

All brackets and handles cannot be removed from V2.3 and newer versions and are part of the front panel front panel.

Visuals

(1) Front



Figure 1: BMPU-R2 V2.1 Front panel



Figure 2: BMPU-R2 V2.3 Front panel

(2) Side



Figure 3: BMPU-R2 V2.1 Right side panel



Figure 4: BMPU-R2 V2.3 Right side panel

(3) Rear

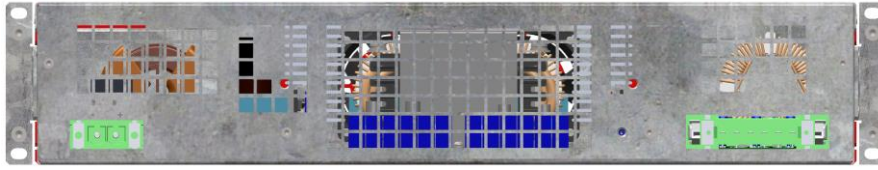

Figure 5: BMPU-R2 V2.1 Rear panel

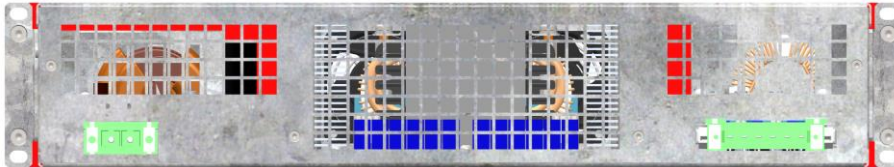
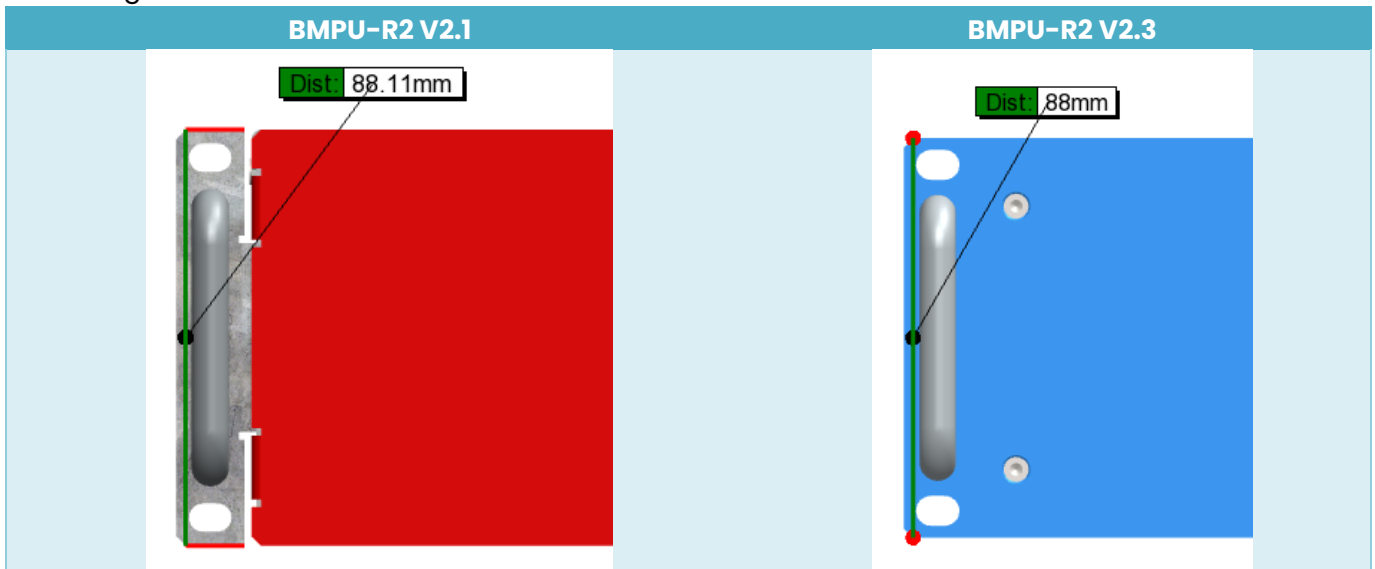

Figure 6: BMPU-R2 V2.3 Rear panel

Dimensions

(1) Height

Changed from 88.11mm to 88mm.



(2) Depth

Changed from 358mm to 360.6mm.

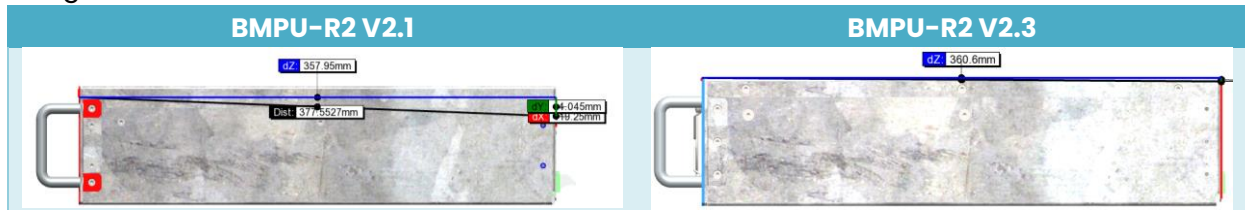

(3) Width

Changed from 450mm to 448.4mm.

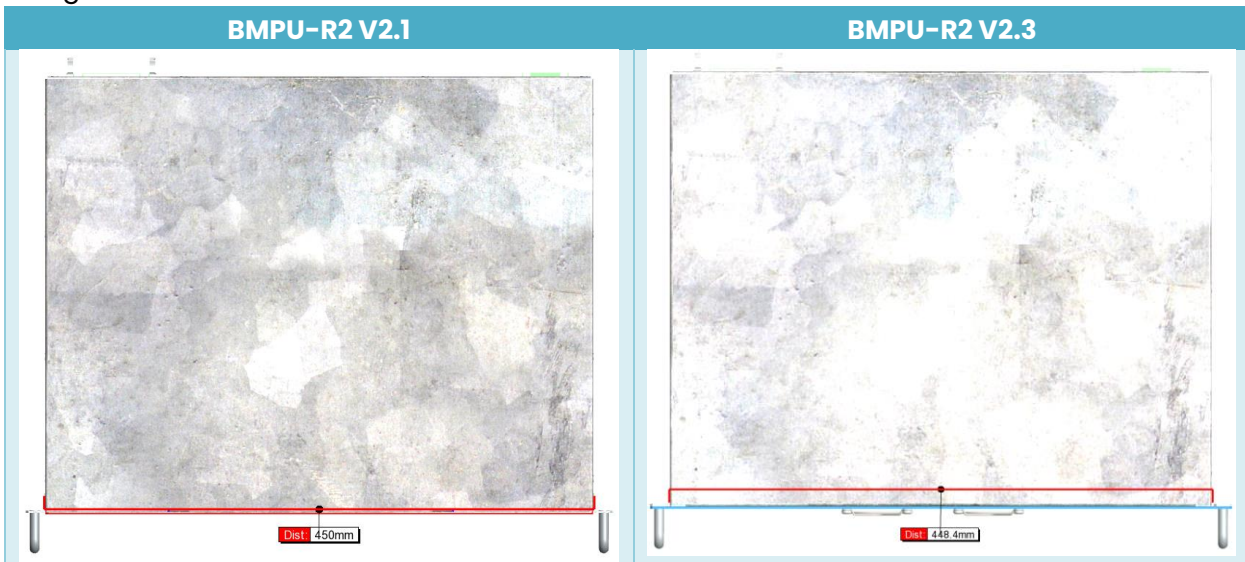

1.1.2. Hardware

LV voltage

In V2.1 a minimum LV input voltage of 14V was required to have optimal usage of the cooling fans. Below this voltage, maximum air cooling is reduced, and thermal derating will occur earlier. This is no longer required in V2.3 and above, where full fan speed can be reached from 9V to 29V input voltage.

EMS logic

In V2.1 EM_SHUT logic is active low:

- “shorted” to GND_ISO: Emergency Shutdown triggered
- “floating”: normal operation

For additional safety, in V2.3 and later, EM_SHUT logic is changed to the following:

- If left “floating”, emergency shutdown is triggered (EM_SHUT=1)
- 12V or 24V: normal operation (EM_SHUT=0)

Addressing connector pinout

Addressing connector pinout has been modified to be compatible with our MPU-Rx chargers' family.

	V2.1	V2.3
PIN	FUNCTION	
1	ADDR0	ADDR0
2	ADDR1	ADDR3
3	ADDR2	ADDR1
4	ADDR3	ADDR4
5	ADDR4	ADDR2
6	GND_ISO	GND_ISO
7	CHARGE_P2	CHARGE_P2
8	UNUSED	UNUSED

Common mode capacitors on AC

Y1 Common mode capacitors on AC side are reduced from 39nF to less than 27nF to safely allow charging with 240Vrms line-to-neutral IT earthing systems with 50Hz as well as 60Hz grid frequency.

1.2. V2.3 to V2.4

V2.4.0 product is compliant with:

- EMI emissions
 - Conducted emissions: class B
 - Radiated emissions class A with 1 turn ferrite FAIR-RITE 0431177081 on AC input port and 1 turn ferrite Wurth Elektronik 74271222 on CAN communication port.
 - Radiated emissions class B with 1 turn ferrite FAIR-RITE 0431177081 on AC input port and 1 turn ferrite Wurth Elektronik 74271222 on CAN communication port and an external filter on LV port. External LV filter proposal: B84112G0000B030 from EPCOS/TDK.
- EMI immunity
 - IEC EN 61000-6-2: Immunity standard for industrial environments
 - IEC EN 61000-6-1: Immunity standard for residential, commercial and light-industrial environments

1.3. V2.4 to V2.5

From V2.5.0 and above, the product passes the EMI emissions and immunity tests as specified in IEC 61000-6-2:2016 and IEC 61000-6-3:2020 with the additions of:

- 1 turn ferrite FAIR-RITE 0431177081 on AC input port,
- 1 turn ferrite FAIR-RITE 0431177081 on DC input port,
- 2 turns ferrite 742 712 22S on CAN communication port,
- 3 turns ferrite 742 712 22S on LV input port.

1.4. CAN address logic for SW versions v2.6.2r and above

From SW version v2.6.2r and above,

If ADDR0= ADDR1= ADDR2= ADDR3= ADDR4=0 → CAN ID=111 (default value)

Else

CAN ID = $80+2^0(\text{ADDR0})+2^1(\text{ADDR1})+2^2(\text{ADDR2})+2^3(\text{ADDR3})+2^4(\text{ADDR4})-1$

2. Absolute maximum ratings

Table 1: Absolute maximum ratings

Parameter	Condition	Min	Max	Units
LV Input Voltage		0	29	V
DC side voltage		0	500	V
AC side voltage (phase-phase)			530	V _{RMS}
Operating Temperature		-10	70	°C
Long term storage Temperature		-30	70	°C
DC output (DC+ or DC-) to PE			±1000	V

Recommended maximum ambient temperature is 45°C, beyond 45°C, linear derating on power output is applied.

3. Electrical Characteristics

All specifications are given for ambient temperature up to 45°C unless otherwise noted.

Table 2: Electrical characteristics

Parameter	Condition	Value			Units
		Min	Typ	Max	
AC side					
Voltage (phase-phase)	V2G or G2V	147	400 or 480	530	V _{RMS}
Voltage (phase to neutral)	V2G or G2V	85	230 or 277	305	V _{RMS}
Current (per phase)		0		16	A _{RMS}
AC Inrush current				42.4	A _{pk}
Input frequency	V2G or G2V	42.5	50	69	Hz
Current measurement accuracy	@16A _{RMS}			5	%
Voltage measurement accuracy	@480V _{LL}			2.3	%
Power factor	Reactive power control	-0.4	0.99	+0.4	-
DC side					
Voltage	G2V (charge) V2G (discharge)	150 250		500	V _{DC}
Power	G2V (charge) V2G (discharge)			10.5 -11	kW
Maximum power variation (SW programmable)	Active power Reactive power			30 5	kW/s kVAR/s
Current	G2V (charge) V2G (discharge)			30 -32	A
Voltage measurement accuracy	@500V			0.5	%
Current measurement accuracy	@ 32A _{dc}			1	%
CAN communication					
CAN baud rate			500		kbps
CAN common mode range ¹		-7		7	V
Digital Inputs					
Positive going input current (Charge permission, Address, EMS)		2		10	mA
Negative going input current (Charge permission, Address, EMS)				0.1	mA
Maximum reverse voltage				5.5	V
LV input					
Supply voltage		10	24	29	V
Power consumption	@10V input @12V input @24V input	5 ² 5 5		39 ³ 36.5 34	W
Input current start-up (inrush)	@24V input during 1ms			30	A

¹ CAN common mode; CAN_H and CAN_L versus CAN_GND

² Standby mode operation

³ Three-phase with neutral operation with fans at full speed

Under Voltage Shutdown			9		V
Insulation					
Input (AC) to output (DC)	50/60 Hz, 1 min		3200		V _{RMS}
Input (AC) to case (PE)	50/60 Hz, 1 min		3200		V _{RMS}
Output (DC) to case (PE)	50/60 Hz, 1 min		1600		V _{RMS}
Touch current AC (TT or TN network)	IP 240VAC+10%, 50Hz			1.1	mA _{RMS}
	IP 240VAC+10%, 60Hz			1.3	
Touch current AC (IT earthing network)	Under a fault between phase and earth				mA _{RMS}
	IP 240VAC+10%, 60Hz			3.4	
	IP 240VAC+10%, 50Hz			2.8	
Y-capacitor AC to PE				27	nF
Y-capacitor DC+ to PE or DC- to PE				42	nF

3.1. Earthing system compatibility

BMPU-R2 charger is compatible with TT, TN and IT earthing systems.

3.2. Safe Operating Area

BMPU-R2 automatically adjusts its operation to the typical operating zone of an EV battery.

A Safe Operating Area (SOA) in three-phase mode (400V_{LL}/50Hz) is given in Figure 7 where two modes can be identified:

- Forward or G2V: currents flow from Grid to the battery (also known as Grid-to-Vehicle)
- Reverse or V2G: current flows from Battery to the grid (also known as Vehicle-to-Grid)

BMPU-R2 can change between both operating modes and go to full power in either direction in less than 750 ms (firmware v2.3.1 or higher required)

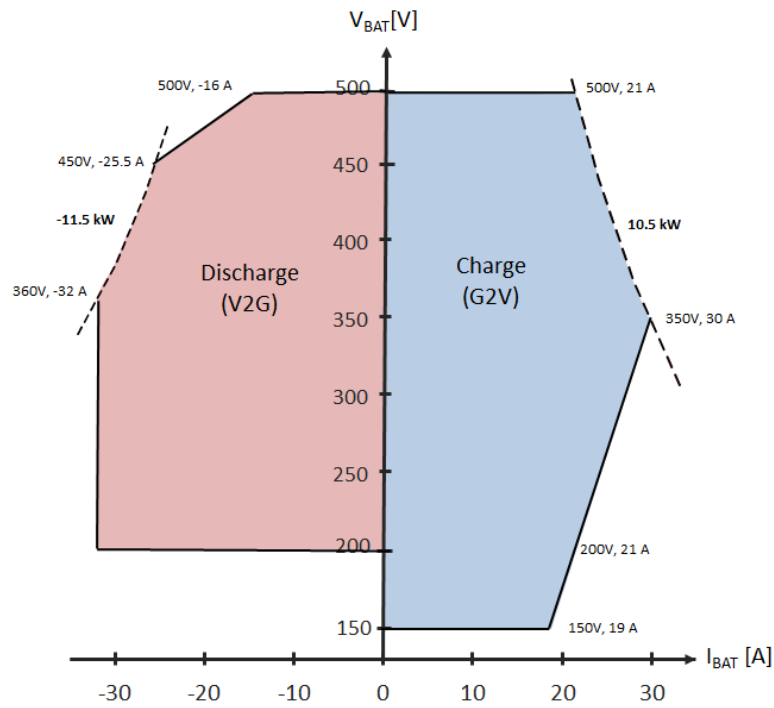

Figure 7: Battery Side Safe Operating Area under grid conditions 400V/50Hz at 25°C

A Safe Operating Area (SOA) in three-phase mode for (480V_{LL}/60Hz) is given in Figure 8.

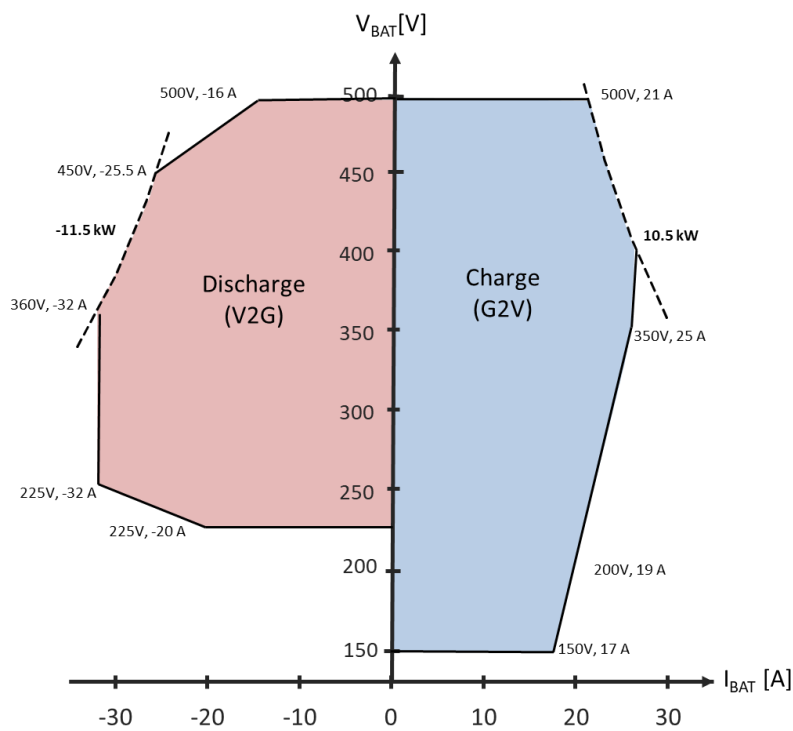

Figure 8 Battery Side Safe Operating Area under grid conditions 480V/60Hz at 25°C

3.3. Typical efficiency

BMPU-R2 is based on highly efficient full SiC (Silicon Carbide) technology. Peak efficiency reaches 96% and efficiency is consistently above 94% for a wide range of battery voltage and current as shown on Figure 9, Figure 10 and Figure 11.

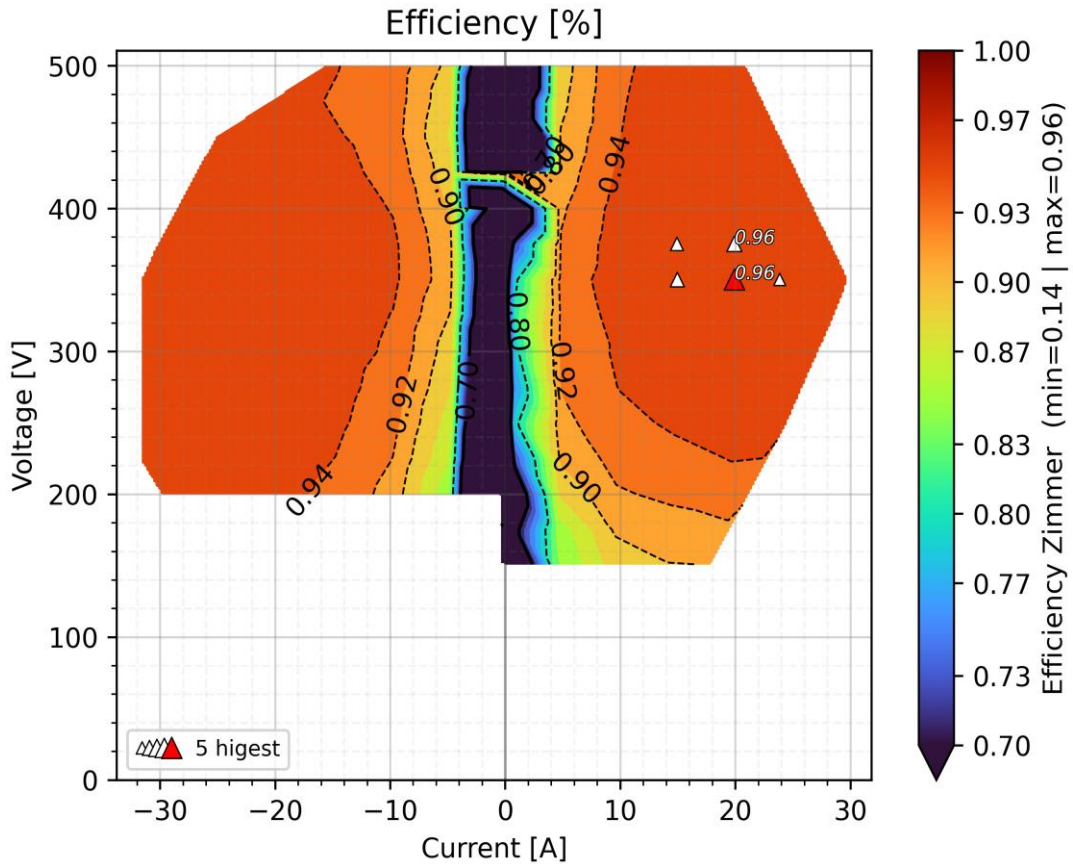

Figure 9: Typical BMPU-R2 efficiency in three-phase mode without neutral under grid conditions 400V/50Hz at 25°C

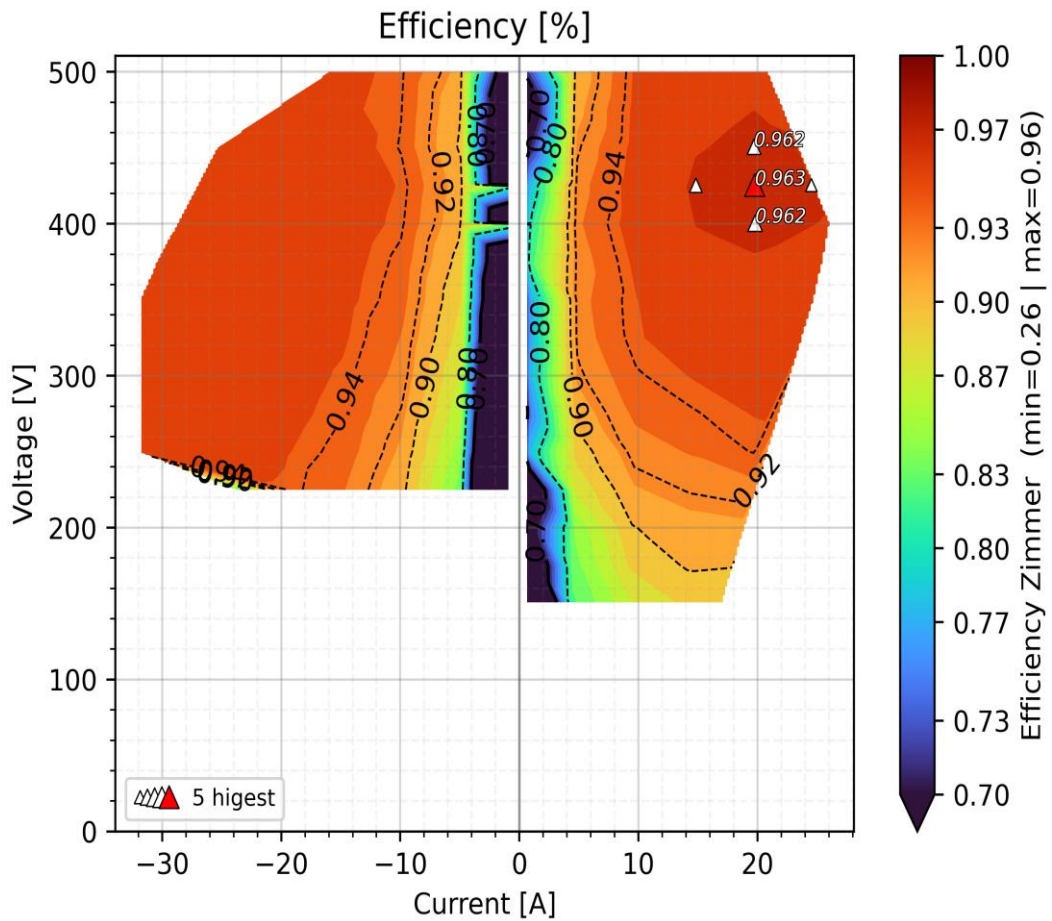

Figure 10: Typical BMPU-R2 efficiency in three-phase mode without neutral under grid conditions 480V/60Hz at 25°C.

The SOA and efficiency mapping plot is given hereafter in case of single-phase operation:

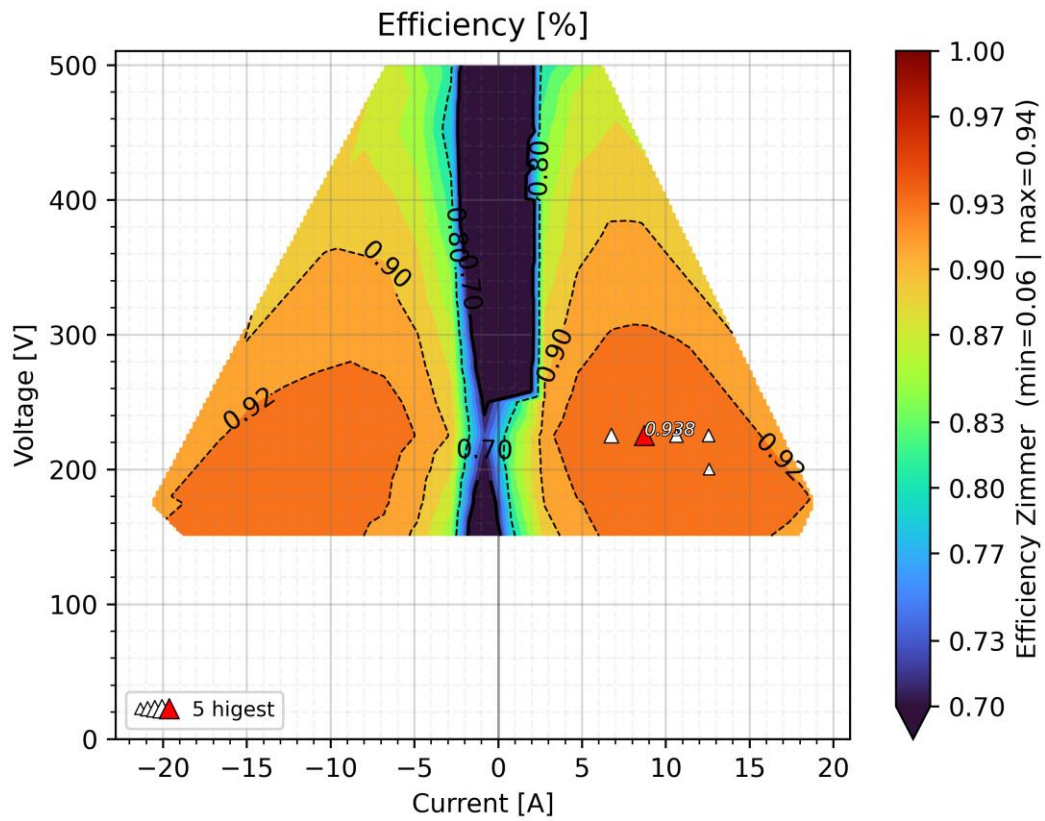

Figure 11: Typical BMPU-R2 efficiency in single-phase mode

3.4. Output power derating

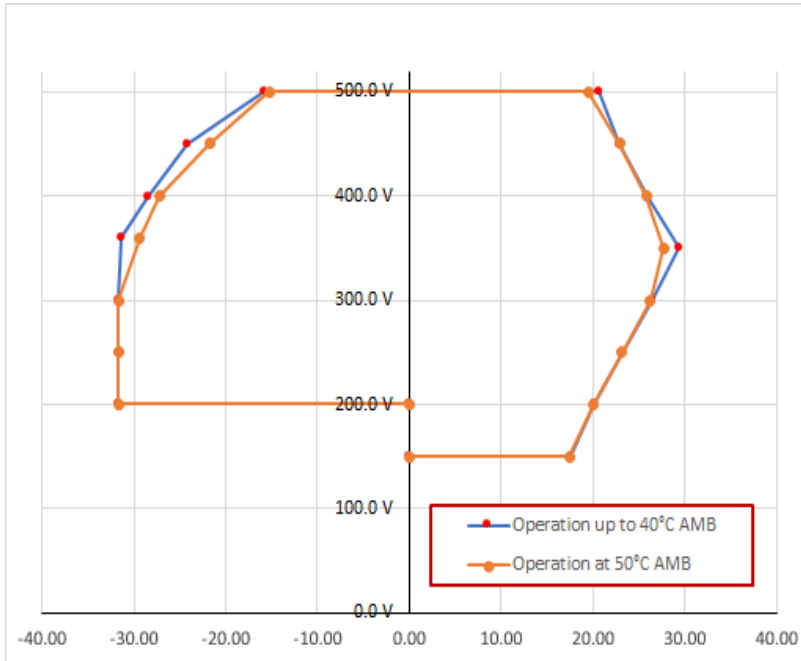

Figure 12: power derating at 50°C ambient

Beyond 45°C, a linear derating of the output power is applied to ensure safe and reliable operation. Derating Rate: 2.27°C/kW

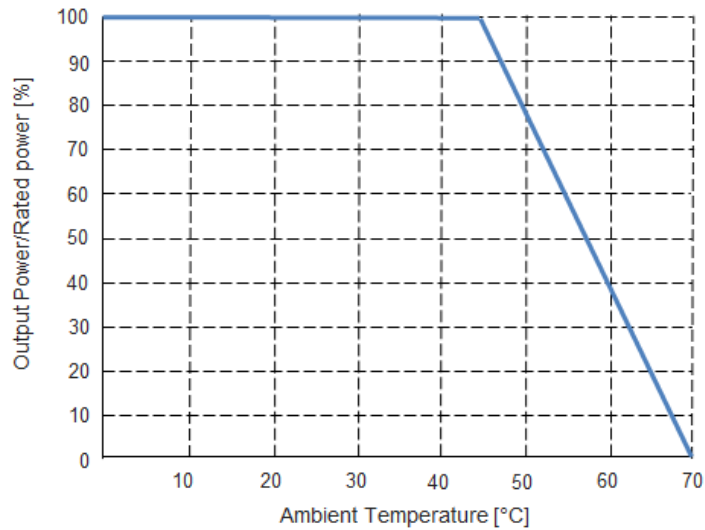

Figure 13: Output power derating in function of ambient temperature

BMPU-R2 is sized for 11kVA (AC side power) at 230V (line to neutral)

- Below 230V, power is limited by max current 16 Arms
- Above 230V, power can be kept constant

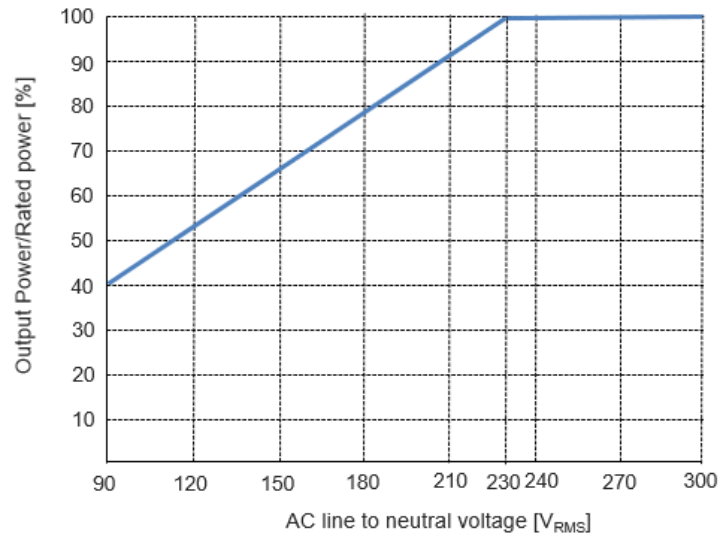

Figure 14: Output power vs AC line voltage (phase-neutral)

3.5. DC current ripple

The current ripple at DC output depends on the operation point. It is given in Figure 15 for three-phase operation 400V/50Hz and SW version 2.5.4r (build 19020).

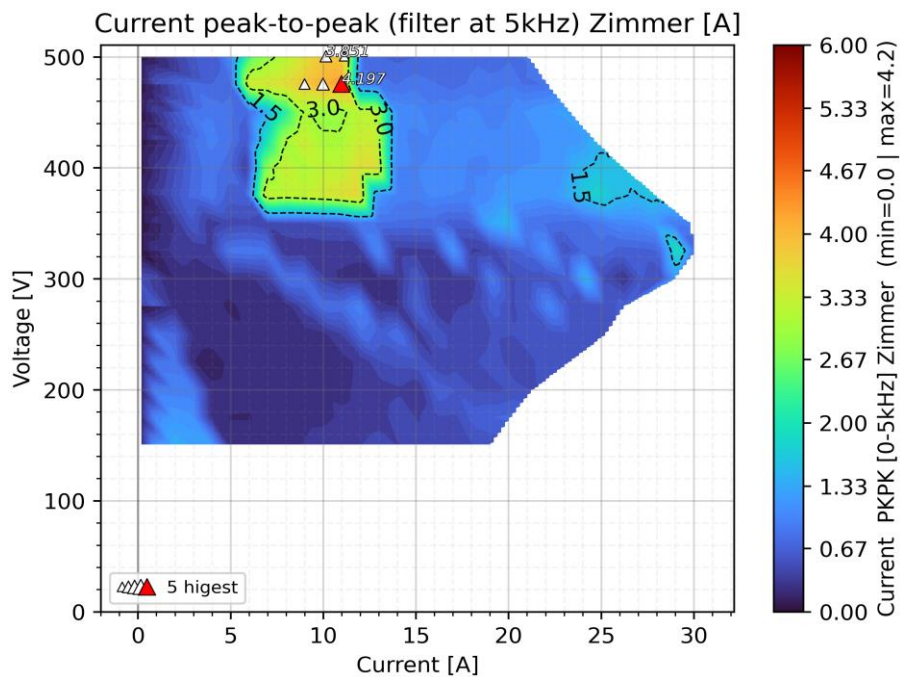

Figure 15: peak-to-peak current ripple at the battery side filtered at 5kHz given for grid conditions three-phase with neutral 400V/50Hz and SW version 2.5.4r (build 19020)

4. Safety instructions

4.1. Caution

The following safety instruction must be observed during all phases of operation, service and repair of this equipment. Failure to comply with the safety precautions or warnings in this documentation violates safety standards of design, manufacture and intended use of this equipment and may impair the built-in protections within WATT & WELL shall not be liable for users to comply with these requirements.

4.2. Installation

BMPU-R2 device must be installed following installation chapter.

This product is a safety Class I instrument. To minimize shock hazard, the instrument chassis must be connected to installation protective earth (safety ground) with the dedicated ground terminal.

The protective earth terminal must be connected to the safety electrical ground before another connection is made. Any interruption of the protective ground conductor, or disconnection of the protective earth terminal will cause a potential shock hazard that might cause personal injury.

BMPU-R2 device is designed to be accessible only for trained staff operators in **restricted access location**.

4.3. Input rating

Do not use power supplies which exceed the input voltage rating of this instrument. The electrical rating of this instrument is given in the chapter 3 of this document.

4.4. Live circuits

Operating personnel are not allowed to open the case of this equipment. Internal adjustment or component replacement is not allowed by non-WATT & WELL qualified personnel. Never replace components with cable connected to this instrument. To avoid injuries, always disconnect power and remove external voltage sources before touching components.

4.5. Hot surface

Surface of the product could be hot during and after operation. Use protection before touching the device.

4.6. Parts substitution and modifications

Parts substitutions and modifications are allowed by authorized WATT & WELL service personnel only.

For repairs or modification, the unit must be returned to WATT & WELL's After Sale Service. Contact After Sale Service (aftersales@wattandwell.com) to obtain a return merchandise authorization (RMA) number.

WATT & WELL
After Sale Service
121 Rue Louis Lumière
84120 PERTUIS
France

4.7. Environmental condition

BMPU-R2 device safety approval applies to the following operating conditions:

- Integrated into EVSE system (in a 19" cabinet or a custom build enclosure)
- Maximum relative humidity : 95% at 40°C non-condensing
- Altitude : up to 2000m
- Pollution degree : 2 ^{Note 4} (Pollution degree 3 possible as an option)
- Overvoltage category : III (4kV) on AC side
: 2.5kV on DC side
: 500V on LV side
- IP degree of enclosure : IP2X



Protective ground conductor terminal

The charging station where BMPU-R2 will be installed should meet the requirements of environmental protection as defined in IEC 61851-1:2019.

The IP degree needs to reach IP44 or above for outdoor use or IP21 for indoor use.

Avoid using the charger in the offshore environment near the sea or near a pollution source or in a corrosive and damaging environment. If you need to use it in the above environment, the protection level of the station needs to reach IP65, otherwise it may lead to the failure of BMPU-R2. This damage caused will not be covered by the warranty.

⁴ Attention should be paid to avoid ingress of water, metallic or conductive particles, dust or corrosive atmospheric that may cause early failures of equipment.

4.8. Normative compliance

The foregoing information relates to product versions V2.4.1 and higher.

The previous versions are non-CE compliant and are considered as evaluation kits destined for professionals to be used solely at research and development facilities for such purposes.

BMPU-R2-500-32 meets the intent of directives:

- Low Voltage: 2014/35/UE
- CEM 2014/30/UE
- RoHS: 2011/65/UE
- WEEE: 2012/19/EU



The compliance was demonstrated to the normative reference:

Normative	Name	Notes
NF EN IEC 61000-6-1	Electromagnetic compatibility (EMC) – Part 6-1: Generic standards – Immunity standard for residential, commercial and light-industrial environments	
NF EN IEC 61000-6-2	Electromagnetic compatibility (EMC) Part 6-2: Generic standards Immunity for industrial environments	
NF EN IEC 61000-6-3	Electromagnetic compatibility (EMC) Part 6-4: Generic standards Emission standard for residential, commercial and light-industrial environments	
NF EN IEC 61000-6-4	Electromagnetic compatibility (EMC) Part 6-4: Generic standards Emission standard for industrial environments	
IEC 61000-3-2	Electromagnetic compatibility (EMC) – Part 3-2: Limits – Limits for harmonic current emissions (equipment input current ≤ 16 A per phase)	
IEC 61000-3-3	Electromagnetic compatibility (EMC) – Part 3-3: Limits – Limitation of voltage changes, voltage fluctuations and flicker in public low-voltage supply systems, for equipment with rated current ≤ 16 A per phase and not subject to conditional connection	
IEC 61000-4-11	Electromagnetic compatibility (EMC) – Part 4-11: Testing and measurement techniques - Voltage dips, short interruptions and voltage variations immunity tests for equipment with input current up to 16 A per phase	Criterion B
IEC 61000-4-28	Electromagnetic compatibility (EMC) – Part 4-28: Testing and measurement techniques – Variation of power frequency, immunity test	Criterion A
IEC 61000-4-6:2013	Conducted RF Fields	10Vrms AC line, DC power out, LV power in
IEC 61000-4-4:2012	Electrical fast transient/burst immunity test AC power line	± 2 KV

IEC 61000-4-5:2014	Surge immunity test AC power line	±2KV common mode ±1KV differential mode
IEC 61000-4-8:2009	Power frequency magnetic field immunity test	30A/m criterion A
IEC 61000-4-3:2006 /AMD1:2007/AMD2:2010	Radiated, radiofrequency, electromagnetic field immunity test	Industrial Level
IEC 61000-4-2:2008	Electrostatic discharge immunity test	±4KV contact ±8KV air discharges
CISPR 16-2-1:2014/AMD1:2017	Conducted emission AC line	Class B
CISPR 16-2-3:2016	Radiated emission	Class B ⁵

Please also note that **BMPU-R2-500-32** is designed to be compatible with the following norms:

Normative	Name	Notes
IEC 61851-1:2019 (ed 3.0)	Electric vehicle conductive charging system Part 1: General requirements	
IEC 61851-23 (ed 1.0)	Electric vehicle conductive charging system Part 23: DC electric vehicle charging station	
IEC 61851-23/AC1 2016	Corrections of IEC 61851-23 ed1.0 (2014)	

However, it is the user's responsibility to ensure that BMPU-R2 is installed and used in compliance with all local country laws and regulations.

BMPU-R2 is also VDE-AR-N 4105 certified :

BMPU-R2 also integrates several grid codes functions, including those of :

- EN 50549
- IEEE 1547-2003

The compliance to most these grid codes have been demonstrated. Please contact us for detailed status.

⁵ with 1 turn ferrite FAIR-RITE 0431177081 on AC input port, 1 turn ferrite FAIR-RITE 0431177081 on DC input port, 2 turns ferrite Wurth Elektronik ferrite 742 712 22S on CAN communication port and 3 turns ferrite Wurth Elektronik ferrite 742 712 22S on LV input port.

5. Installation

Do not use or install BMPU-R2 product in case of visible physical damage.

5.1. Mechanical installation

5.1.1. Handling

BMPU-R2 product has a weight about 14.7 Kg. For correct handling, follow instruction below:

- The product must be handled flat.
- For operator safety use personal protective equipment.
- Do not stack units (each unit should be self-supported and secured with the front and rear brackets)

5.1.2. Mounting

BMPU-R2 can be mounted on standard 19" cabinets.

Note that the BMPU-R2 is a heavy instrument and requires the cabinet to be equipped with slides or rails that support the chassis along the depth.

Minimum air flow required for air cooling is 2.8 m³/min (100 CFM)

Recirculating of hot air should be minimized by ensuring fresh (cold) on the input (see Figure 16). In addition, minimum distances for air cooling are:

- 15 cm for front side
- 9 cm for rear side

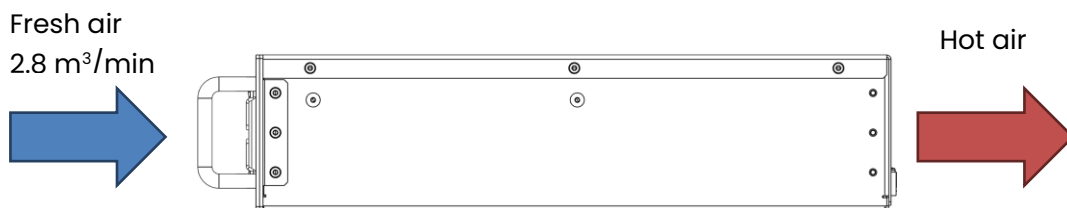

Figure 16: Air flow direction

5.2. Electrical installation

5.2.1. Legal installation

Electrical installation shall comply with international standards such as IEC or the requirements in national standards of each country.

5.2.2. Safety Notice

Never invert the polarity of the connector. Never force to place a connector. Use only approved manufacturer parts for electrical or mechanical connection.

It is strongly recommended to fix the cables to avoid any stress on the connection. All high-power connectors must be screwed up to avoid any disconnection.

Be careful if other devices are connected, there is a risk of electrical charge transfer.

It is forbidden to open the cover. Only W&W approved personnel are allowed to do maintenance operation. waiting time after complete suppression of input voltage before opening the device should be respected.

5.2.3. Protective earth

The protective earth (PE) terminal must be connected to the safety electrical ground before another connection is made. Any interruption of the protective ground conductor, or disconnection of the protective earth terminal will cause a potential shock hazard that might cause personal injury or death. Protective earth connection is made through AC input connector.

Use the protective earth terminal with minimal characteristics:

- Wire section (minimum): 4 mm²

In addition, all parts of the chassis where BMPU-R2 is to be installed (i.e., the 19" cabinet) need to be grounded. An electrical connection to PE through mechanical parts must be made.

5.2.4. AC input

AC input is defined as three phases and neutral line.

BMPU-R2 product must be protected against short circuits, overload protection and earth leakage current protection with external devices.

AC input wires must be connected through a residual current breaker (RCB) and a circuit breaker with short circuit protection and thermal overload protection:

- Class B recommended. Class A is also possible since all grid inputs are double isolated from PE.
- Earth leakage 30mA (lower rating also possible, please consult factory)
- Current rating 20 A
- Number of contacts:
 - o 4 in case of three-phase with neutral operation
 - o 3 is enough if only three-phase without neutral operation is considered

5.2.5. LV DC input

LV input must be connected to 12Vdc or 24Vdc bus. This input must be protected with an adequate fuse.

This cable must be shorter than 3m.

5.2.6. DC Output

DC output is galvanically isolated from protective earth.

This cable must be shorter than 3 m.

5.2.7. EMI requirements

Converters up to V2.3 are not compliant with IEC 61000-6-1/2/3/4 standards and are considered as evaluation kits destined for professionals to be used solely at research and development facilities for such purposes.

However, Integrator is responsible to use best practice for final system to avoid high EMI emissions.

V2.4.1 is compliant with:

- EMI emissions
 - Conducted emissions: class B
 - Radiated emissions class A with 1 turn ferrite FAIR-RITE 0431177081 on AC input port and 1 turn ferrite Wurth Elektronik 74271222 on CAN communication port
 - Radiated emissions class B with 1 turn ferrite FAIR-RITE 0431177081 on AC input port and 1 turn ferrite Wurth Elektronik 74271222 on CAN communication port and an external filter on LV port. External LV filter proposal: B84112G0000B030 from EPCOS/TDK
- EMI immunity
 - IEC EN 61000-6-2: Immunity standard for industrial environments
 - IEC EN 61000-6-1: Immunity standard for residential, commercial and light-industrial environments

From V2.5.0 and above, the product passes the EMI emissions and immunity tests as specified in IEC 61000-6-2:2016 and IEC 61000-6-3:2020 with the additions of:

- 1 turn ferrite FAIR-RITE 0431177081 on AC input port,
- 1 turn ferrite FAIR-RITE 0431177081 on DC input port,
- 2 turns ferrite 742 712 22S on CAN communication port,
- 3 turns ferrite 742 712 22S on LV input port.

5.2.8. Series operation

With the firmware update V2.5.5 or later, Series operations of BMPU-R2 is allowed in G2V and V2G modes.

5.3. Disposal



(Mandatory application within the European Union)

Do not dispose of electronic tools together with household waste material. In accordance with WEEE European Directive (2012/19/UE), Electric material that has reached the end of their life must be collected separately and return to an environmentally compatible recycling facility. Please contact WATT & WELL for any questions about WEEE

6. Hardware specification

6.1. Theory of operation

BMPU-R2 consist of 2 power converting stages:

- Bidirectional Active Front End (or PFC) that interfaces the AC grid. This PFC uses a **four-phase** topology specifically designed and patented for V2X operation handles both three-phase with neutral control (11 kW, 16A) and single-phase capable of up to 7.2kW, 32A
- DC/DC converter that performs galvanic isolation and DC side regulation. It is based on a full SiC resonant topology

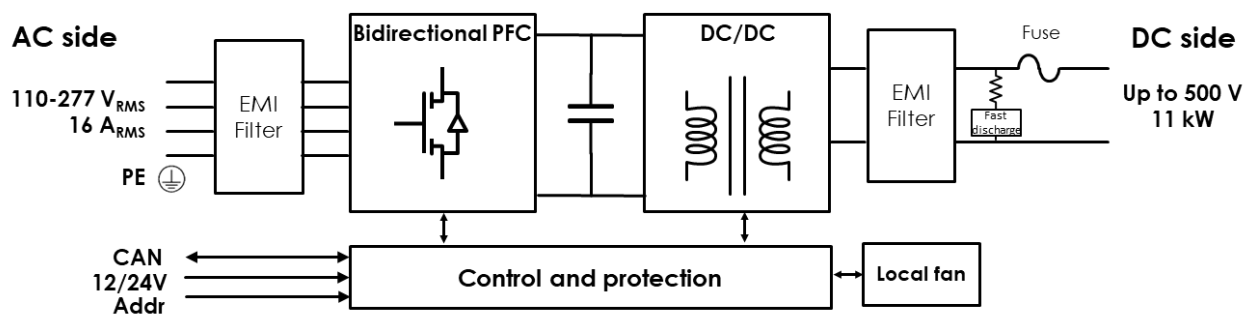

Figure 17 BMPU-R2 11 kW high level synoptic

With the firmware update V2.5.6 or later, this charger enables parallel operation in V2L (Vehicle-to-Load) mode up to 22kW, allowing to create a three-phase electrical network for various applications.

6.2. Interfaces

6.2.1. Low voltage connector

Located on the front panel. Cable connected to these ports must be less than 3m long.

LV connector is used to supply power to fans and control independently of the DC or AC supplies.

Connector Reference (converter side): Phoenix Contact MSTB 2,5/ 2-GF-5,08 1776508

Recommended matting connectors (wire harness side):

Side	Connector	Manufacturer	Wire	Ferrule	Crimping tool
LV	MSTB 2,5/ 2-STF-5,08 – 1777989 (Screw terminal)	Phoenix contact	0.8mm ² (18AWG)	x	x

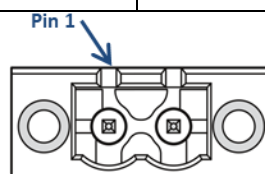

Figure 18: Low voltage connector

PIN	FUNCTION	DESCRIPTION	Preferred wiring color
1	LV_IN-	Low Voltage supply return (0V typ)	Black
2	LV_IN+	Low Voltage supply (24V typ)	Red

6.2.2. AC side connector

Located on the back panel.

Connector Reference (converter side): Phoenix Contact DFK-PC 5/ 6-GF-7,62 – 1727731

Recommended matting connectors (wire harness side):

Side	Connector	Manufacturer	Wire	Ferrule	Crimping tool
AC	SPC 5/ 6-STF-7,62 Ref: 1996168	Phoenix contact	4mm ²	3200959	Crimpfox DUO16S Ref 1202877

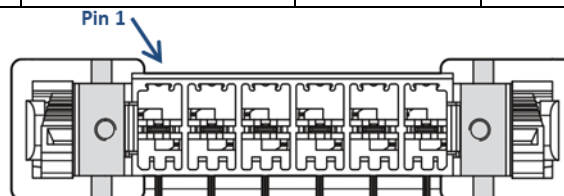

Figure 19: AC connector

Table 3: Pin configuration of the AC connector for 16Arms three-phase operation

PIN	FUNCTION	DESCRIPTION	Preferred wiring color
1	L1	Mains line 1	Brown
2	L2	Mains line 2	Black
3	L3	Mains line 3	Grey
4	L4	Neutral	Blue
5	PE	Protective Earth	Green/yellow striped
6	NC	Not connected	-

Table 4: Pin configuration of the AC connector for 16Arms single-phase operation

PIN	FUNCTION	DESCRIPTION	Preferred wiring color
1	L1	Mains line 1	Brown
2	NC	Not connected	-
3	NC	Not connected	-
4	L4	Neutral	Blue
5	PE	Protective Earth	Green/yellow striped
6	NC	Not connected	-

Table 5: Pin configuration of the AC connector for 32Arms single-phase operation

PIN	FUNCTION	DESCRIPTION	Preferred wiring color
1	L1	Mains line 1	Brown
2	L2	Mains line 1	Brown
3	L3	Neutral	Blue
4	L4	Neutral	Blue
5	PE	Protective Earth	Green/yellow striped
6	NC	Not connected	-

6.2.3. DC side connectors

Located on the back panel. Cable connected to these ports must be less than 3m long.

Connector Reference (converter side): Phoenix Contact: DFK-PC 6-16/ 2-GF-SH-10,16 1701935

Recommended matting connectors (wire harness side):

Side	Connector	Manufacturer	Wire	Ferrule	Crimping tool
DC	SPC 16/ 2-STF-10,16 Ref: 1711378	Phoenix contact	10mm ²	3200551	Crimpfox DUO16S Ref 1202877

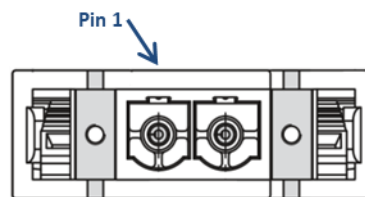
Figure 20 - DC_OUT connector

PIN	FUNCTION	DESCRIPTION	Preferred wiring color
1	DC_OUT-	DC Output return (0)	Black
2	DC_OUT+	DC Output (positive)	Red

6.2.4. COM connector

BMPU-R2 features a galvanically isolated CAN bus for digital communications with other boards. The COM connector is an RJ45 connector. Cable connected to these ports must be less than 3m long.

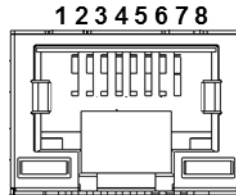

Figure 21: COM connector front view

Table 6: COM connector pinout

PIN	FUNCTION	DESCRIPTION
1	CAN H	CAN differential +
2	CAN L	CAN differential -
3	GND_ISO	Ground reference for CAN
4	EM_SHUT_RTN	Emergency Shutdown return line (negative)
5	EM_SHUT	Emergency Shutdown (positive)
6	NC	Not Connected
7	GND_ISO	Ground reference for CAN
8	ES_R/W	Read/write pin in case of daisy chained power units (Mandatory to keep floating)

Note on CAN bus termination: CAN bus is expected to be terminated at each bus end with a 120 Ω resistance. Wiring should be selected to have an intrinsic impedance of the twisted that match this 120 Ω .

By default, BMPU-R2 does not include any 120 Ω resistor to avoid overloading the bus when multiple nodes are present.

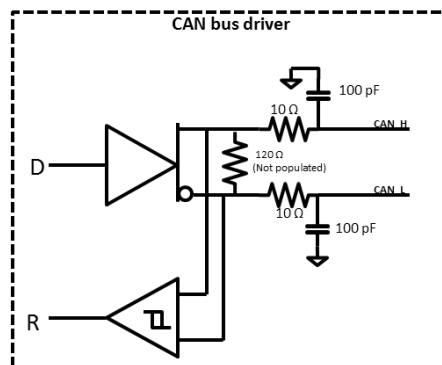

Figure 22: CAN transceiver simplified diagram

Note on CAN bus shield: Although ISO 11898-2 does not specify the wires type or the need for a shield, a shielded cable is recommended for electronically harsh environments. It is recommended to ground the shield at a single point on the dedicated shield pin of the COM connector to avoid ground loops. Also, remember that the CAN bus being isolated, the CAN_GND should be wired between nodes.

6.2.5. Emergency Shutdown

The COM connector also transmits an **Emergency Shutdown** (EM_SHUT) signal. This signal can be used to trigger an unconditional shutdown of the BMPU-R2 operation. See Table 6 for the pinout of EM_SHUT within the COM connector.

In addition, a fast discharge circuit is enabled to discharge the internal output capacitors to a safe level ($\ll 60V$) in less than 1 second.

EM_SHUT logic is as follows:

- “floating”: Emergency Shutdown triggered (EM_SHUT=1)
- 12V or 24V: normal operation (EM_SHUT=0)

The simplified circuit of the EM_SHUT is given in Figure 23.

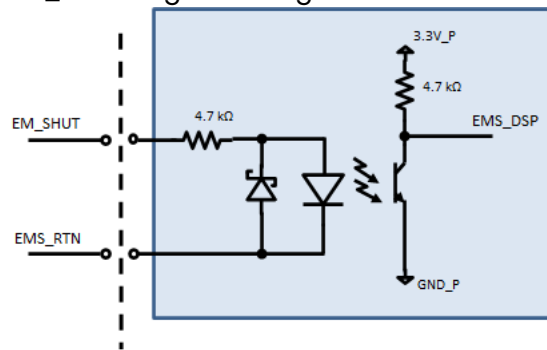

Figure 23 EMS input circuit

6.2.6. Address selector and Charge Permission.

Each BMPU-R2 takes its CAN **address** at boot based on the Addressing connector on the front panel.

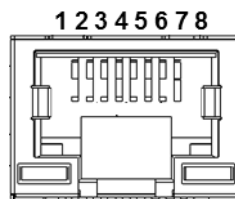

Figure 24: Addressing connector (RJ45) front view

Table 7: Addressing connector pinout

PIN	FUNCTION	DESCRIPTION
1	ADDR0	Address bit 0
2	ADDR3	Address bit 3
3	ADDR1	Address bit 1
4	ADDR4	Address bit 4
5	ADDR2	Address bit 2
6	GND_ISO	Return
7	CHARGE_P	Charge Permission
8	UNUSED	Not used

Each BMPU-R2 takes its CAN address at boot based on the Addressing connector on the front panel.

Up to 32 units can be addressed with 5 DSI (digital signal inputs).

Default value of each unconnected line is logic '0'. An addressing line tied to GND_ISO is logic '1'.

If ADDR0= ADDR1= ADDR2= ADDR3= ADDR4=0 → **CAN ID=111** (default value)

Else

CAN ID = $80+2^0(\text{ADDR0})+2^1(\text{ADDR1})+2^2(\text{ADDR2})+2^3(\text{ADDR3})+2^4(\text{ADDR4})-1$

ADDR4	ADDR3	ADDR2	ADDR1	ADDR0	CAN ID (dec)
0	0	0	0	0	111
0	0	0	0	1	80
0	0	0	1	0	81
0	0	0	1	1	82
0	0	1	0	0	83
0	0	1	0	1	84
0	0	1	1	0	85
0	0	1	1	1	86
0	1	0	0	0	87
0	1	0	0	1	88
0	1	0	1	0	89
0	1	0	1	1	90
0	1	1	0	0	91
0	1	1	0	1	92
0	1	1	1	0	93
0	1	1	1	1	94
1	0	0	0	0	95
1	0	0	0	1	96
1	0	0	1	0	97
1	0	0	1	1	98
1	0	1	0	0	99
1	0	1	0	1	100
1	0	1	1	0	101
1	0	1	1	1	102
1	1	0	0	0	103
1	1	0	0	1	104
1	1	0	1	0	105
1	1	0	1	1	106
1	1	1	0	0	107
1	1	1	0	1	108
1	1	1	1	0	109
1	1	1	1	1	110

Please note that the address 111 must not be used if multiple units are present.

If EVI board is used as main controller 16 units can be addressed.

	CAN ID (dec)	CAN ID (hex)	ADDR4	ADDR3	ADDR2	ADDR1	ADDR0
BMPU 0	94	0x5E	0	1	1	1	1
BMPU 1	95	0x5F	1	0	0	0	0
BMPU 2	96	0x60	1	0	0	0	1
BMPU 3	97	0x61	1	0	0	1	0
BMPU 4	98	0x62	1	0	0	1	1
BMPU 5	99	0x63	1	0	1	0	0
BMPU 6	100	0x64	1	0	1	0	1
BMPU 7	101	0x65	1	0	1	1	0
BMPU 8	102	0x66	1	0	1	1	1
BMPU 9	103	0x67	1	1	0	0	0
BMPU 10	104	0x68	1	1	0	0	1
BMPU 11	105	0x69	1	1	0	1	0
BMPU 12	106	0x6A	1	1	0	1	1
BMPU 13	107	0x6B	1	1	1	0	0
BMPU 14	108	0x6C	1	1	1	0	1
BMPU 15	109	0x6D	1	1	1	1	0

Both CAN and addressing connectors transmits optional DSI (digital signal input)

“**Charge Permission**” signal: CHARGE_P2. This signal can be used as a redundant stop signal in such way MPU-R2 stops operation when it receives a stop instruction by either “Charge Permission signal” or “CAN communication message”. This functionality helps achieve compliance with safety features of some EV charging protocols like CHAdeMO. It is disabled by default.

When Charge Permission is enabled, logic levels are defined as

- ‘0’ or floating: no output (forbidden operation). If a start message is received by CAN, a fault will be generated.
- ‘1’ or shorted to GND_ISO: charge permission OK (system can start if a CAN message is received)

“**ES_R/W**” signal: should be kept floating by user on CAN connector side. It is used to disable the charging process of all units chained together in case of a fault on one unit.

LEDs: 4 LEDs on front panel indicate the status of the system.

Table 8 – LED overview

LED	NAME	COLOR	FUNCTION	Description
1	FLT	Red	Fault	Indicates a fault in the system. Systems is stopped as a result
2	DC	Blue	DC output	<ul style="list-style-type: none"> • Continuous: System in G2V mode • Blinking at 5Hz: (only in V2G/G2V) AC voltage is out of range. Output power is set off and the charger remains waiting for AC voltage to return within acceptable range.
3	AC	Blue	AC output	<ul style="list-style-type: none"> • Continuous: System in V2G or V2L modes)
4	RDY	Yellow	Voltage presence	<ul style="list-style-type: none"> • Slow blink: Auxiliary voltage only (12V) • Continuous: Grid voltage and Aux voltage

6.2.7. Protective Earth

Protective Earth is connected through the AC input connector in the rear panel to the rack chassis.

7. Control specifications

7.1. Theory of operation

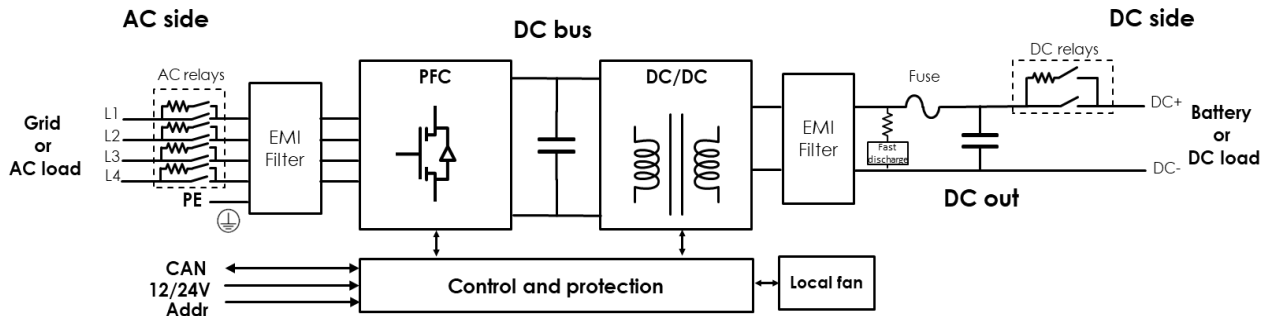

Figure 25 Converter synoptic

The control system of BMPU-R2 consists of the following aspects:

- Overall behavior of BMPU-R2 is determined by a state machine that defines the possible actions of the converter depending on user state request and selected power mode.
- PFC control system that regulates phase currents, reactive power and DC bus voltage in G2V/V2G operations and the AC voltage and frequency is V2L operation. It
- DCDC control system that regulates AC active power, battery side current and voltage.
- Software protections against over/under-voltage, over/under current, over-temperature, communication loss...etc.
- DC out fast discharge control
- CAN communication based on CANopen protocol
- Relays management, fan speed control and LEDs lighting.

7.2. User inputs

7.2.1. Nominal operation

BMPU-R2 uses a fully digital, microcontroller-based regulator. This approach allows a very flexible control of the system. Figure 26 shows the regulation parameters that must be set through CAN messages to achieve the desired operating point. These parameters are defined as follows.

1. **State request:** The State Request word is used to request a state change. Four actions can be requested by the user as described in the following table

State	Definition
Standby	System stopped and power off
Power On	System pre-charged and ready to start
Charging	Charge is ongoing
Fault Ack	Fault acknowledgement

2. **Power mode:** selection of operating power mode:
 - **G2V/V2G – AC power control mode:** charger is current-controlled source where AC side active and reactive powers are controlled.
 - **G2V/V2G – DC voltage control mode:** charger is current-controlled source where DC side voltage is controlled. Active and reactive powers are not controlled.
 - **V2L mode:** charger is voltage-source inverter (VSI) where AC side voltage and frequency are controlled (voltage and frequency targets are defined by user)
3. **Grid configuration:** selection of phases number
 - Single-phase 16 A per phase (L1 as phase and L4 as neutral)
 - Single-phase 32 A per phase (L1//L2 as phase and L3//L4 as neutral)
 - Three-phase (L1, L2 and L3 as phases)
 - Three-phase with neutral (L1, L2 and L3 as phases and L4 as neutral)

These configurations are available for G2V/V2G mode and V2L mode.

4. **AC current limitations:** limitation of AC currents per phase (not effective in V2L mode)
5. **Charging current limitation:** limitation of charging current (effective in G2V mode)
6. **Discharging current limitation:** limitation of discharging current (effective in V2G and V2L modes)
7. **Active power setpoint:** Active power target (Active only in G2V/V2G –AC power control mode).
 - Positive value requests charger to operate in V2G mode
 - Negative value requests charge to operate in G2V mode
8. **Reactive power setpoint:** Reactive power target
 - Positive value requests capacitive behavior (current leads the voltage)
 - Negative value requests inductive behavior (current lags the voltage)
9. **DC voltage setpoint:** Battery side voltage target
 - In DC voltage control mode: if DC voltage setpoint is higher than the battery voltage, the charger operates in G2V. If the DC voltage setpoint is lower than the battery voltage, the charger operates in V2G.
 - In AC power control mode: the DC voltage setpoint must be always higher than the battery voltage to allow the control of the AC power. Otherwise, the charger operates in V2G, if the DC voltage setpoint is lower than the battery voltage whatever the value of the AC power setpoints.
10. **AC voltage setpoint:** AC voltage target in V2L mode

11. AC frequency setpoint: AC frequency target in V2L mode

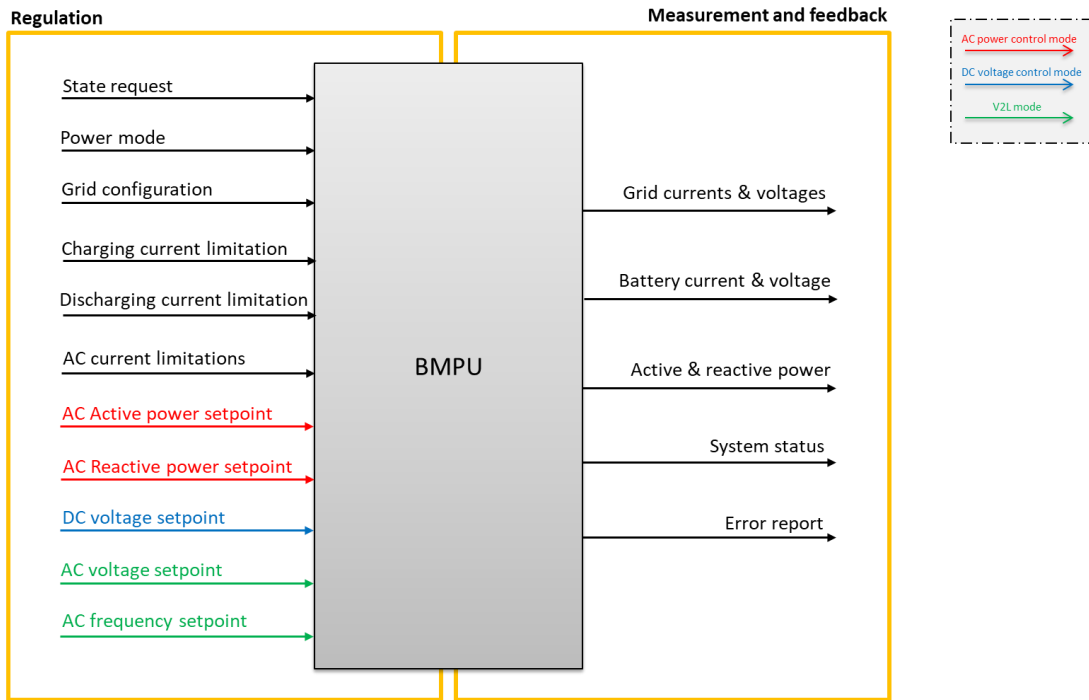

Figure 26: High level charger regulations and measurements



WARNING

Setpoint inputs dedicated to one mode are not effective in another. For example, AC Active power setpoint has no impact on active power in DC voltage control mode. Equally, DC voltage setpoint is not considered in AC power control mode and battery voltage is not controlled in this case.

Charging and discharging current limitations can be overridden by system limitations as thermal derating, battery maximum power...etc.

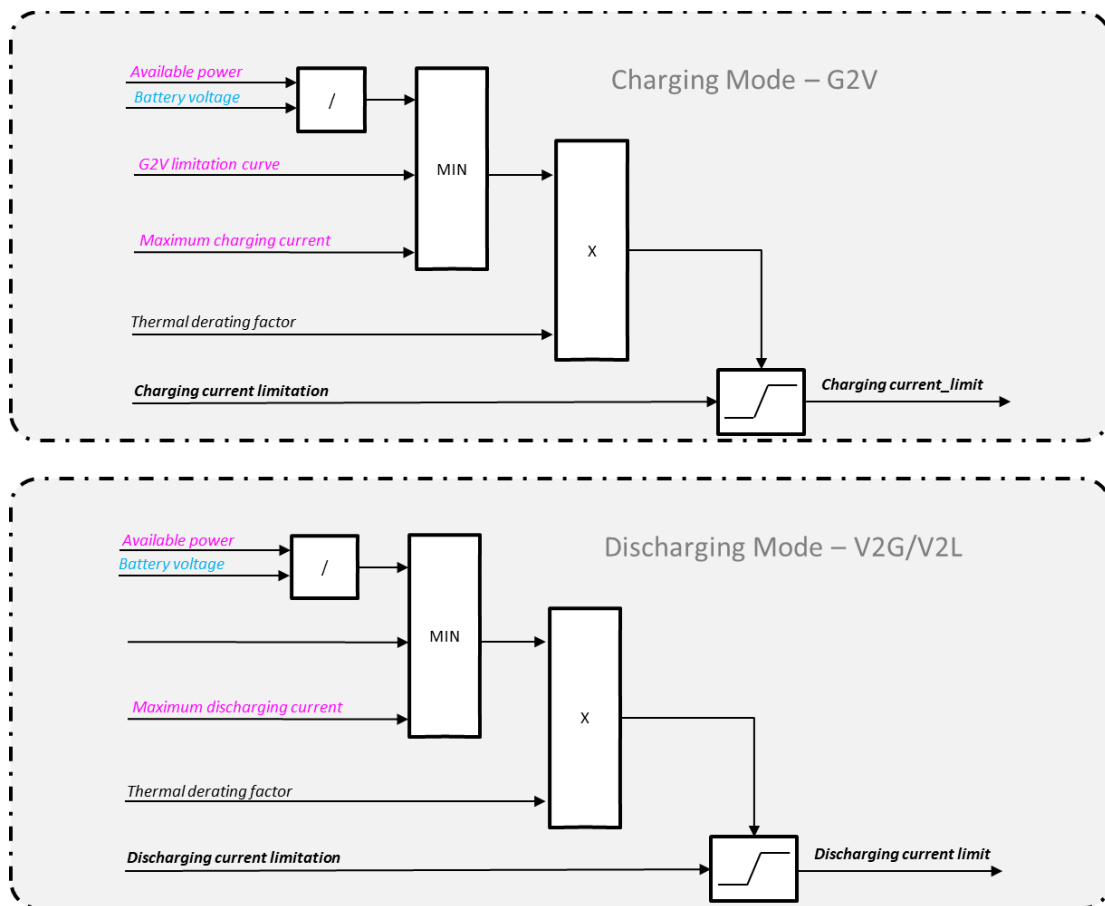

Figure 27 Charging and discharging current limitations

With

- **Charging current limitation:** limitation setpoint requested by user
- **Discharging current limitation:** limitation setpoint requested by user
- **Maximum charging current:** set to 30A by default
- **Maximum discharging current:** set to 32A by default
- **G2V limitation curve:** lookup table based on AC voltage derating (for grid voltage > 240 Vrms) and DC voltage derating (for battery voltage < 350V)
- **V2G limitation curve** lookup table based on AC voltage derating (for grid voltage > 240 Vrms) and DC voltage derating (for battery voltage > 450V)
- **Available charging/discharging power:** it is calculated as follows.

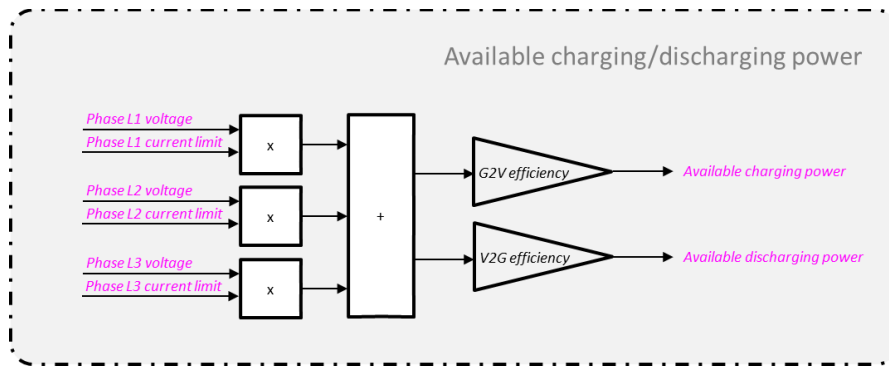

Figure 28 Available charging/discharging power

- thermal_derating_factor:** Thermal derating consists of derating delivered power linearly between derating start temperature threshold and shutdown temperature. The derating is applied by reducing the charging or discharging current by a thermal derating factor. This factor is the product of three factors driven from each type of temperature as shown in figure below. Thermal protection thresholds are defined based on component (mosfets, magnetics...etc) temperature specifications, experimental mapping, and sensors accuracy.

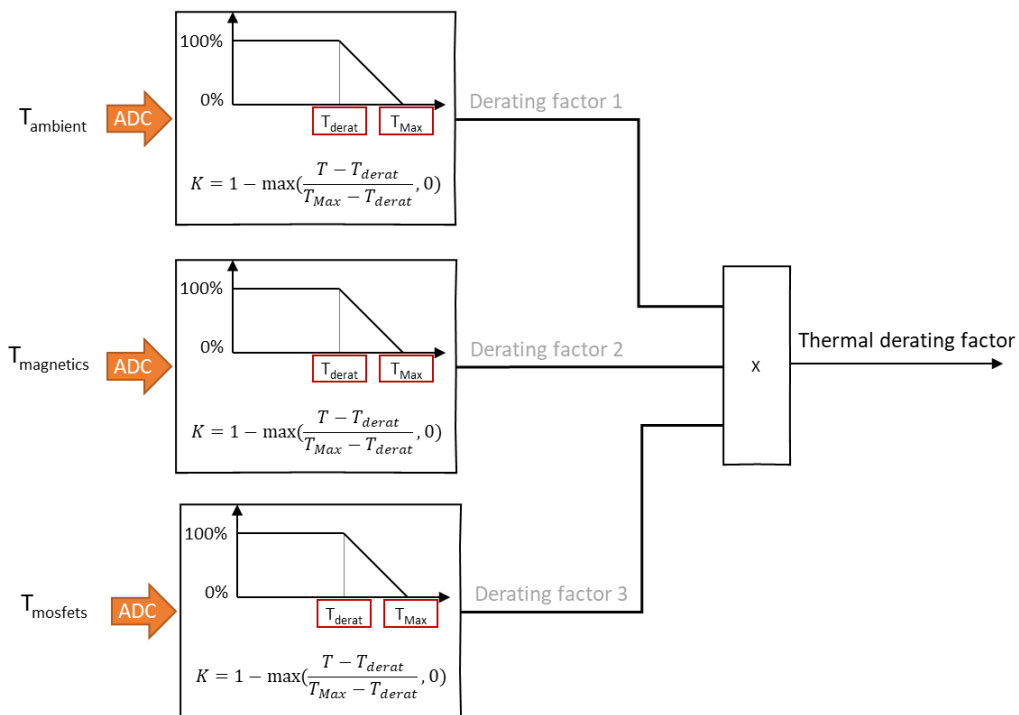

Figure 29 Thermal derating

Please note that changing the protection thresholds by the user is very risky and may result to the destruction of the product.

7.2.2. Special operation

Extra power mode

This mode allows the charger to deliver 12.5kW in charging and discharging modes for several seconds.

To activate the extra power mode, the following changes should be made:

- put the parameter having the index 0x4100 and subindex 0x39 (Derating_special_start_temp) to 1.
- Charging current limitation set to 35
- Discharging current limitation set to -35

V2L parallel operation

V2L Parallel mode is based on clusters with master/slave architecture. The communication is set with the master and the cluster is seen as one unit.

To activate this mode, please:

- Set the parameter with the index 0x4100 and subindex 0x01 "number_of_distant_pu" to the number of slave units (for example to 1 if only two units: 1 slave + 1 master). The maximum number of slaves is 7.
- 3 Clusters of 8 units (1 master + 7 slaves) are available. The master units must take one of the following addresses: 80, 88, or 96. A cluster of maximum 7 units (1 master + 6 slaves) is available with the address 104.
- The slaves CAN address should be set to:
 - Master CAN address +1 for slave 1 (for example: 81 for slave 1 of a master at 80)
 - Master CAN address +2 for slave 2
 - ...etc

Please note:

- The load should only be connected **AFTER** "Charge" state is enabled.
- To stop charging, the load **MUST** be disconnected first. Then, request "StandBy" to the master unit.

If the DC ports of one pair of BMPU-R2 units are serialized, the index 0x4100 and subindex 0x3B (dcdc_series_mode) must be set to 1 on all the units forming the cluster.

For more details, please check the application note "**BMPU-series AN007 - V2L in parallel operation**".

VDE-AR-N 4105 compliance mode

This mode allows the charger to integrate VDE-AR-N 4105 functionalities.

To activate this mode, put the parameter having the index 0x4100 and subindex 0x3C (grid_code_active) to 1.

IMPORTANT: Please note that the generator convention system of current and voltage used in VDE-AR-N 4105 is:

Power setpoints sign convention

- Default sign convention

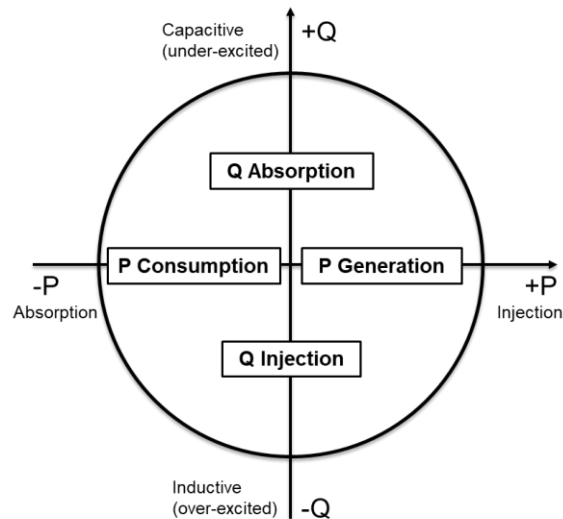

Figure 30: Power setpoint sign convention

- The sign convention can be inverted by setting the parameter with the index 0x4100 and subindex 0x3E "power_sign_convention" to 1.

7.3. User outputs

The system returns measured current, voltage, active and reactive power for each phase. It also returns battery current, voltage, and power. Feedback is given on the system status and errors are reported in the fault word. Refer to section 7.4 for details on fault word in Table 17.

The status of the state machine is indicated in the System State bits within Status Word (see Status word definition). Possible values are detailed in Table 12.

Available values of active, reactive power and current are returned by the converter. They are calculated based on AC voltage, battery voltage, thermal derating and user-defined maximum values. Refer to TPDOs list in section 7.4 for available quantities.

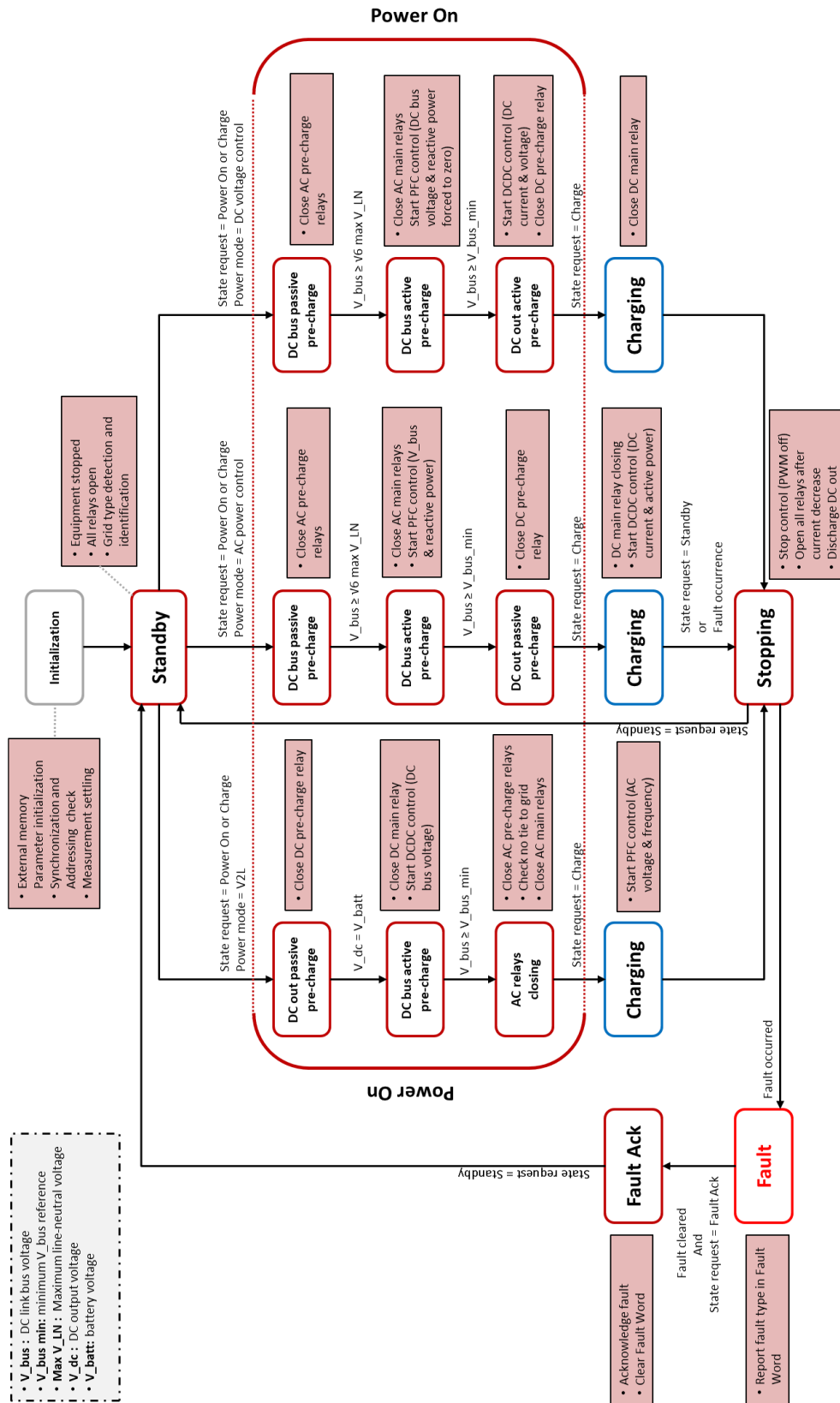

Figure 31: Charger State Machine

7.4. CAN communication

CAN Network: The CAN network is composed of at least 2 nodes; Control master node and the BMPU-R2 charger node

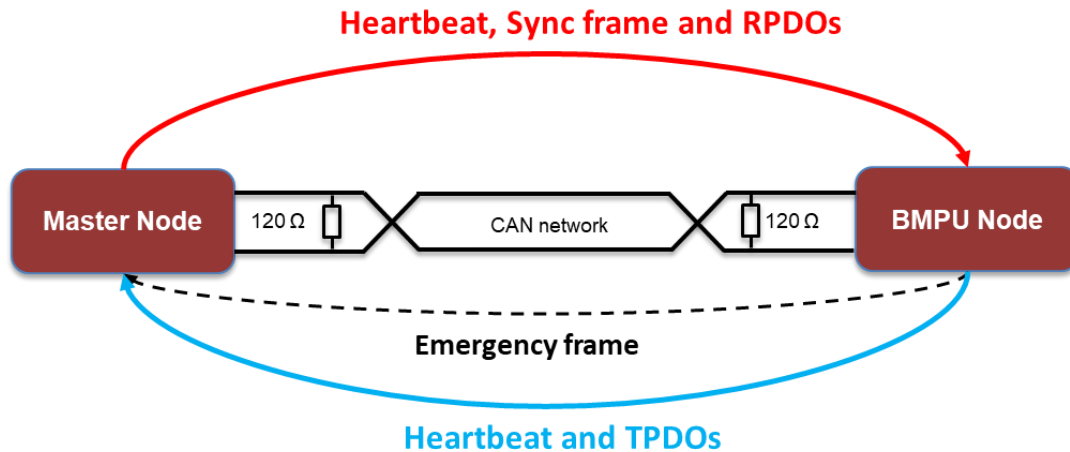

Figure 32: CAN network illustration

BMPU-R2 charger is controlled by RPDO messages where regulation inputs (as illustrated in Figure 32) are transmitted from the Master node to the charger control unit.

Master node receives measurement and feedbacks from the charger via TPDOs messages. Synchronization message (sync frame) must be sent from the Master to charger to enable TPDOs transmission.

BMPU-R2 charger transmits periodically to the master a heartbeat frame to notify its presence on the network. Similarly, it must receive the master heartbeat frame periodically, otherwise charger goes to fault mode due to CAN communication timeout.

In case of error, charger send an emergency frame to notify its fault mode.

Node IDs and messages data are detailed in the following paragraphs.

CAN baud rate: CAN 2.0A cadenced at 500kbit/s with little endian byte order.

Node ID: See section **Address selector** in section Address selector and Charge Permission.. Default address is x50 (80).

Frame ID: Frame IDs are defined by the relation: Frame ID = Node ID + ID offset
In what follows default node ID x50 is considered and ID offset is given for every frame.

Heartbeat frame: Charger automatically transmits its communication state at regular intervals as evidence of its communication ability. This frame is sent by charger every 1 sec.

Charger also consumes the heartbeat of its master (expected to have the nodeID 0x1). So, the master shall emit every 1 second a heartbeat frame with an *operational* status. If this frame is not received by the charger, the charge will be stopped, and the charger will go into fault state.

Node	Frame ID	ID offset	DLC	Byte 0
Charger	x750	x700	1	ChargerStatus
Master	x701	X700	1	MasterStatus

- Status = 0 at bootup (1 frame with 0 to be sent at boot)
- Status = 5 when node communication stack is operational (to be sent periodically)
- Status = 4 when node communication stack is stopped (to be sent periodically)
- Status = 127 when node communication stack is pre-operational (to be sent periodically)

Sync frame: To trig synchronous sending of TPDO frames, charger must receive SYNC message.

Frame ID	DLC
x80	0

It is recommended to send it every 50 ms.

Transmit Process Data Object (TPDO)

Frame ID	ID offset	DLC	Byte 0	Byte 1	Byte 2	Byte 3	Byte 4	Byte 5	Byte 6	Byte 7
x1D0	x180	8	itfc_current_state				itfc_critical_fault_word			
x2D0	x280	8	itfc_v_batt_max	itfc_i_batt_max		itfc_i_grid_max		itfc_P_grid_max		
x3D0	x380	8	itfc_pos_active_available_power	itfc_neg_active_available_power		itfc_pos_reactive_available_power		itfc_neg_reactive_available_power		
x4D0	x480	8	itfc_v_L1mL4_rms	itfc_i_L1_rms		itfc_P_L1		itfc_Q_L1		
x1B0	X160	8	itfc_v_L2mL4_rms	itfc_i_L2_rms		itfc_P_L2		itfc_Q_L2		
x2B0	X260	8	itfc_v_L3mL4_rms	itfc_i_L3_rms		itfc_P_L3		itfc_Q_L3		
x3B0	X360	8	itfc_v_grid	itfc_i_grid		itfc_P_grid		itfc_Q_grid		
x4B0	X460	8	itfc_v_batt	itfc_i_batt		itfc_P_batt		itfc_available_i_batt		

- TPDOs data description is given in Table 10.

- Each TPDO is transmitted after reception of N number of Sync message. This number is defined by the transmission type parameter of the TPDO. For B MPU R2, transmission type for TPDOs is defined in the following table.

Table 9 TPDOs transmission type

TPDO ID	Transmission type
x1D0	1
x2D0	1
x3D0	1
x4D0	1
x1B0	1
x2B0	1
x3B0	1
x4B0	1

For example, when using transmission type 34, the TPDO is transmitted after every 34th Sync message.

Emergency frame: Emergency frame sent by charger in case of default.

Frame ID	ID offset	DLC	Byte 0	Byte 1	Byte 2	Byte 3	Byte 4	Byte 5	Byte 6	Byte 7
X0D0	x80	8	Error code		Error register	Unused	Data			

- Error Code: 0xFF01 if the charger went to safeD. Other Error codes due to communication stack are defined by CANopen.
- Error Register: In case of SafeD error, to be ignored.
- Data: In case of SafeD error, data = CriticalFaultWord, else, to be ignored.

Receive Process Data Object (RPDO): The RPDO frames are the charger control frames. Charger state, mode, grid configuration and setpoints (control targets and limitations) are communicated to the charger via the control frames.

Frame ID	ID offset	DLC	Byte 0	Byte 1	Byte 2	Byte 3	Byte 4	Byte 5	Byte 6	Byte 7
x250	x200	8	itfc_pfc_state_request	itfc_pfc_mode_request	itfc_grid_conf_request	itfc_v2l_frequency_setpoint	itfc_v2l_voltage_setpoint		itfc_battery_voltage_setpoint	
x350	x300	8	itfc_i_charge_limit		itfc_i_discharge_limit		itfc_active_power_setpoint_W		itfc_reactive_power_setpoint_VAR	
X450	x400	6	itfc_i_L1_limit		itfc_i_L2_limit		itfc_i_L3_limit			

- RPDOs data description is given in Table 10.

Data units and type definition: Messages data types and units are defined in the table below:

Table 10: Frame data definition

Signal	Definition	LSB value	Unit	Data type	r/w (from master point of view)	Frame
itfc_pfc_state_request	Power state request: StandBy, PowerOn, Charge	See Request word def	NA	Uint8	w	RPDO0
itfc_pfc_mode_request	Mode request: G2V/V2G (power or voltage control) or V2L	See Request word def	NA	Uint8	w	RPDO0
itfc_grid_conf_request	Grid configuration request: Single/ three phase	See Request word def	NA	Uint8	w	RPDO0
itfc_v2l_frequency_setpoint	V2L mode frequency target	1	Hz	Uint8	w	RPDO0
itfc_v2l_voltage_setpoint	V2L mode AC voltage target	0.1	V	Unit16	w	RPDO0
itfc_battery_battery_setpoint	DC side voltage target in G2V/V2G voltage control mode	0,1	V	Unit16	w	RPDO0
itfc_i_charge_limit	DC charging current limit	0,1	A	Unit16	w	RPDO1
itfc_i_discharge_limit	DC discharging current limit	0,1	A	Unit16	w	RPDO1
itfc_active_power_setpoint	Active power target in G2V/V2G power control mode	10	W	int16	w	RPDO1
itfc_reactive_power_setpoint	Reactive power target in G2V/V2G modes	10	VAR	int16	w	RPDO1
itfc_i_L1_limit	Phase L1 current limit	0.1	A	Unit16	w	RPDO2
itfc_i_L2_limit	Phase L2 current limit	0.1	A	Unit16	w	RPDO2
itfc_i_L3_limit	Phase L3 current limit	0.1	A	Unit16	w	RPDO2
itfc_current_state	Power state feedback (see Status Word)	See StatusWord def	NA	Uint32	r	TPDO0
itfc_critical_fault_word	Critical fault word	See CriticalFaultWord def	NA	Uint32	r	TPDO0
itfc_v_batt_max	Maximum battery voltage	0,1	V	Unit16	r	TPDO1
itfc_i_batt_max	Maximum battery current	0,1	A	Unit16	r	TPDO1

itfc_i_grid_max	Maximum grid side current	0,1	A	Uint16	r	TPDO1
itfc_P_max	Maximum grid side ppower	10	W	Uint16	r	TPDO1
itfc_pos_active_available_power	Available G2V active power	10	W	int16	r	TPDO2
itfc_neg_active_available_power	Available V2G/V2L active power	10	W	int16	r	TPDO2
itfc_pos_reactive_available_power	Available capacitive reactive power	10	VAR	int16	r	TPDO2
itfc_neg_reactive_available_power	Available inductive reactive power	10	VAR	int16	r	TPDO2
itfc_v_L1mL4_rms	Phase L1 RMS voltage	0,1	V	int16	r	TPDO3
itfc_i_L1_rms	Phase L1 RMS current	0,1	A	int16	r	TPDO3
itfc_P_L1	Phase L1 Active power	10	W	int16	r	TPDO3
itfc_Q_L1	Phase L1 Reactive power	10	VAR	int16	r	TPDO3
itfc_v_L2mL4_rms	Phase L2 RMS voltage	0,1	V	int16	r	TPDO4
itfc_i_L2_rms	Phase L2 RMS current	0,1	A	int16	r	TPDO4
itfc_P_L2	Phase L2 Active power	10	W	int16	r	TPDO4
itfc_Q_L2	Phase L2 Reactive power	10	VAR	int16	r	TPDO4
itfc_v_L3mL4_rms	Phase L3 RMS voltage	0,1	V	int16	r	TPDO5
itfc_i_L3_rms	Phase L3 RMS current	0,1	A	int16	r	TPDO5
itfc_P_L3	Phase L3 Active power	10	W	int16	r	TPDO5
itfc_Q_L3	Phase L3 Reactive power	10	VAR	int16	r	TPDO5
itfc_v_grid	Overall grid voltage	0,1	V	int16	r	TPDO6
itfc_i_grid	Overall grid current	0,1	A	int16	r	TPDO6
itfc_P_grid	Overall active power	10	W	int16	r	TPDO6
itfc_Q_grid	Overall reactive power	10	VAR	int16	r	TPDO6
itfc_v_batt	Overall battery voltage	0,1	V	int16	r	TPDO7
itfc_i_batt	Overall battery current	0,1	A	int16	r	TPDO7
itfc_P_batt	Overall battery side power	10	W	int16	r	TPDO7
itfc_available_i_batt	Available battery current	0.1	A	int16	r	TPDO7

Status word definition

Table 11: Status Word

Bit	Flag name	Flag definition
0:3	SystemState	State, see SystemState_e enum explanation
4:7	SystemSubState	SubState, see SystemSubState_e enum explanation
8:10	SystemDcdcState	DCDC state, see SystemDcdcState enum explanation
11:12	SystemMode	Mode, see SystemMode enum explanation
13:15	SystemConfiguration	Configuration, see SystemConfiguration enum explanation
16	CurrentRegulationFlag	Set to 1 if PU is limited by max Current
17	VoltageRegulationFlag	Set to 1 if PU is limited by max Voltage
18	ActivePowerRegulationFlag	Set to 1 if PU is limited by max active Power
19	ReactivePowerRegulationFlag	Set to 1 if PU is limited by max reactive Power
20	MaxBatteryChargingCurrentFlag	Set to 1 if PU is limited by max charging current
21	MaxBatteryDischargingCurrentFlag	Set to 1 if PU is limited by max discharging current
22	SafeCFlag	Set to 1 if phase voltages are not within the static voltage range
23	PfcOnFlag	Set to 1 if PFC is ON
24	DcdcOnFlag	Set to 1 if DCDC is ON
25	InputCurrentLimitationFlag	Set to 1 if PU is limited by input current
26	FaultMaskStatusLog	Set to 1 if fault word mask value is not the default value
27	ThermalLimitationFlag	Set to 1 if PU is limited by thermal heating
28	GridDetectionFlag	Set to 1 if Grid is detected
29	Discharging flag	Set to 1 if PU is discharging
30	Unused1	Unused
31	AggregatedPusFlag	Set to 1 if it is a master Pu in charge of 1 or several distant (slave Pus)

Table 12: System states definition

Value	Name	Definition
0	STATE_INIT	System is starting
1	STATE_STANDBY	Power is off, system waits a request
2	STATE_POWER_ON	System ready to start
3	STATE_CHARGE	Charge is ongoing
4	STATE_SAFE_D	Critical fault occurred; system halted in this mode until user action.
5	RESERVED	For future use
6	STATE_STOPPING	Converter is stopping and power is being killed off
7	STATE_LOCK_DSP	The state machine waits for DCDC to be in Standby mode
8	STATE_FAULT_ACK	Fault acknowledgement

Some intermediate sub-states exist in the state machine that are also accessible through the status word. Although these sub-states are transparent to the user, they are documented on Table 13 for completeness.

Table 13: System Sub State definition

Value	Name	Definition
0	SUBSTATE_INIT	System initialization
1	SUBSTATE_STANDBY	Power is off
2	SUBSTATE_STANDBY_PASSIVE_PRECHARGE	Precharge relays are set ON to allow passive pre-charge
3	SUBSTATE_STANDBY_PASSIVE_PRECHARGE_DRIVER_ON	Passive pre-charged is completed, power legs pwm drivers are on.
4	SUBSTATE_STANDBY_ACTIVE_PRECHARGE	DC link voltage and soft start conditions are checked, system starts PFC closed loop control to complete active pre-charge
5	SUBSTATE_PFC_CHARGING	DCDC is ready and charging starts in V2G and G2V modes
6	SUBSTATE_SAFE_C	System is stopped and remains waiting for Safe C condition clearance
7	SUBSTATE_VSI_ACTIVE_PRECHARGE	DCDC is requested to pre-charge DC link bus for V2L operation
8	SUBSTATE_VSI_CHARGING	DCDC is ready and charging starts in V2L mode
9	SUBSTATE_STOPPING	System is requested to stop; power is still on
10	SUBSTATE_SAFE_D	Critical fault occurred, system halted in this mode until fault clearance or STANDBY request.
11	SUBSTATE_LOCK_DSP	The ACDC waits for DCDC Standby mode status
12	SUBSTATE_FAULT_ACK	Fault acknowledgement

The DCDC converter is supervised by an inner state machine that is controlled by the charger state machine. The DCDC states are presented in Table 14: DCDC states definition

Table 14: DCDC states definition

Value	Name	Definition
0	STATE_DCDC_INIT	System is starting
1	STATE_DCDC_STANDBY	Power is off, system waits a request
2	STATE_DCDC_POWER_ON	System ready to start
3	STATE_DCDC_CHARGE	Charge on going
4	STATE_DCDC_SAFE_D	Critical fault occurred; system halted in this mode until user action.
5	STATE_DCDC_STOPPING	Converter is stopping and power is being killed off
6	STATE_DCDC_LOCK_DSP	The DCDC waits a request for Standby mode
7	STATE_DCDC_FAULT_ACK	DCDC fault acknowledgement

The operating mode as voltage inverter (V2L), voltage-controlled rectifier (G2V/V2G) or power-controlled rectifier (G2V/V2G) must be requested by SystemMode whose values are described in Table 15: System mode definition.

Table 15: System mode definition

Value	Name	Definition
0	MODE_UNKNOWN	Operation mode is not specified, system remains in stand by state
1	MODE_VSI	Voltage source inverter (VSI) mode for V2L operation
2	MODE_PFC_POWER	Power factor corrector (PFC) mode for G2V/V2G operations with constant current control on battery side
3	MODE_PFC_VOLTAGE	Power factor corrector (PFC) mode for G2V/V2G operations with constant voltage control on battery side

Grid configuration must be determined prior to any charger utilization. It can be either detected automatically or user defined for G2V/V2G operations. For V2L, it must be user-defined. Grid configuration is requested by SystemConfiguration with the values defined in Table 16: System configuration definition

Table 16: System configuration definition

Value	Name	Definition
0	CONF_UNKNOWN	Grid configuration is not specified, system remains in stand by state.
1	CONF_SINGLE_PHASE_TWO_WIRE	Single-phase configuration L1 as phase and L4 as neutral
2	CONF_SINGLE_PHASE_FOUR_WIRE	Single-phase configuration with L1+L2 as phase and L3+L4 as neutral
3	CONF_THREE_PHASE_THREE_WIRE	Three-phase configuration without neutral wire
4	CONF_THREE_PHASE_FOUR_WIRE	Three-phase configuration with neutral wire

SystemMode and SystemConfiguration can be changed only during STATE_STANDBY. This is to prevent any modification during power operations.

Critical Fault Word Code

In order to prevent system from failure event which could damage product, BMPU-R2 has several security faults. These faults statuses are indicated in bit-wise word "CriticalFaultWord" and is defined as follows:

Table 17: CriticalFaultWord definition

Bit	Fault name	Fault definition
0	Over_current_L1	Over-current protection on phase L1
1	Over_current_L2	Over-current protection on phase L2
2	Over_current_L3	Over-current protection on phase L3
3	Over_current_L4	Over-current protection on phase L4
4	Over_voltage_L1	Over-voltage protection on phase L1
5	Over_voltage_L2	Over-voltage protection on phase L2
6	Over_voltage_L3	Over-voltage protection on phase L3
7	Over_voltage_L4	Over-voltage protection on phase L4
8	Over_frequency	Over-frequency protection
9	Under_frequency	Under-frequency protection
10	Anti_Islanding	Anti-Islanding protection
11	Ov_v_bus	Over-voltage protection on DC-link Bus
12	Ov_v_batt	Over-voltage protection on battery
13	UV_v_batt	Under-voltage protection on battery
14	OC_i_batt	Over-current protection on battery
15	Over_Temp_dc_dc_prim	Thermal shutdown on DCDC grid side mosfets
16	Over_Temp_dc_dc_sec	Thermal shutdown on DCDC battery side mosfets
17	Over_Temp_pfc	Thermal shutdown on PFC mosfets
18	Over_Temp_transformer	Thermal shutdown on DCDC transformer
19	Over_Temp_ambient	Thermal shutdown on ambient temperature
20	OVRT_disconnection	Grid disconnection after over-voltage ride through
21	UVRT_disconnection	Grid disconnection after under-voltage ride through
22	OVP_Aux_LV	Over-voltage protection on LV auxiliary power supply
23	UVP_Aux_LV	Under-voltage protection on LV auxiliary power supply
24	emergency_shutdown	Emergency shutdown input triggered
25	device_timeout	No reception of master heartbeat frame for more than timeout period
26	dc_dc_pfc_com_loss	Communication loss between PFC and DCDC
27	dc_dc_pfc_com_errs	Communication errors between PFC and DCDC
28	chargeP	No charge permission input (only in DC voltage control mode)
29	address_selection	No valid address selected
30	precharge_failure	DC-link bus pre-charge not completed during allowed time or voltage drops below the passive pre-charge maximum voltage.
31	OV_Regul_v_batt	Regulation loss of battery voltage (only in DC voltage control mode)

8. Mechanical specifications

BMPU-R2 measures 448.4 × 88 × 360.6 mm (excluding connectors and handles).

By default, side brackets with handles are added on front face to be mounted as a standard 19" rack 2U tall.

Brackets on rear panel (see WA018 in Related products) can be added for additional support. On request, handles can be removed for a more compact integration, and customized front face is available to reduce its width from 480 mm to 448.4 mm.

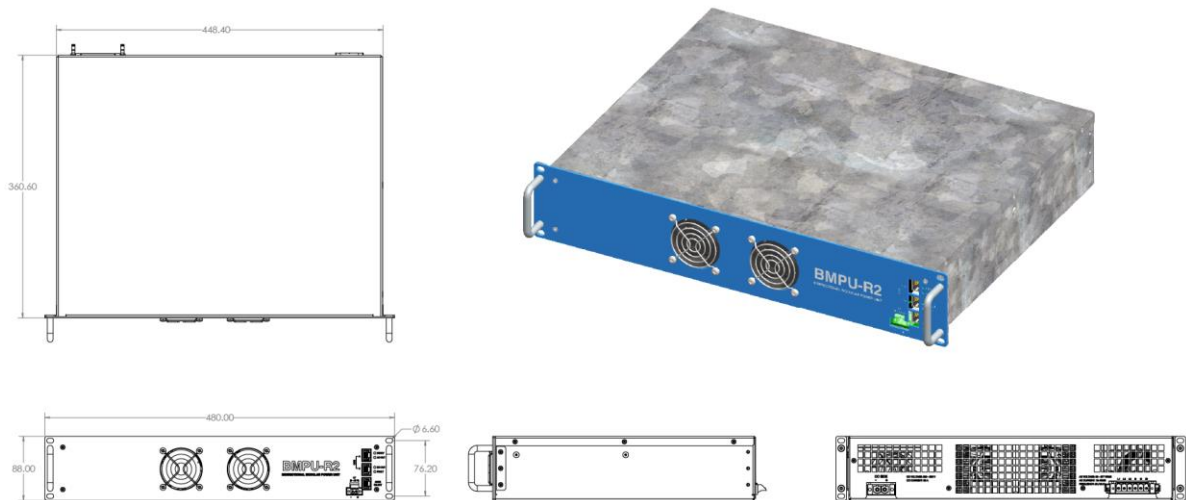

Figure 33: BMPU-R2 assembly drawing (with default real panel support)

9. Maintenance

It is forbidden to open the product.

9.1. Cleaning

Use a soft cloth for cleaning the device. Do not use cleaning agent.

Internal dust could be removed with vacuum cleaner or dry air cleaning.

9.2. Cooling fan

Cooling fans are internally controlled. Do not obstruct apertures on the case side.

9.3. Fuse replacement

DC side is protected by an adequate fuse.

Fuse replacement is only allowed by WATT & WELL qualified personnel. Return product to factory for replacement.

10. Ordering information

10.1. Product Reference

	Status	P	AC side	DC side
BMPU-R2-500-32	Active	11 kVA	3 Φ +N	500V, 32A

The product will be shipped in a cardboard box H 210, W 470, L 550 (15 Kg)

10.2. Product accessories

<p><u>WA012 – Set of matting connectors BMPU-R2</u> AC side (1996168), DC side (1711378) and LV side (1873207). Unwired</p>	
<p><u>WA013 – Pre-wired AC harness 32A BMPU-R2</u> with 6mm² color-coded wire and IEC 60309 32A plug (3P+N+PE) Cable length: 2.5m</p>	
<p><u>WA005 – Pre-wired DC harness</u> with 10mm² color-coded wire and M6 lug termination Cable length: 2.5m</p>	
<p><u>WA016 – Pre-wired LV harness</u> With color-coded 4mm insulated banana plug Cable length: 2.5m</p>	
<p><u>WA018 – Bracket without handle (set of 2)</u> Can be mounted on rear side to provide additional support</p>	
<p><u>WA007 – CAN bus adaptor from RJ45 to DB9</u> including 120 Ω termination resistance</p>	

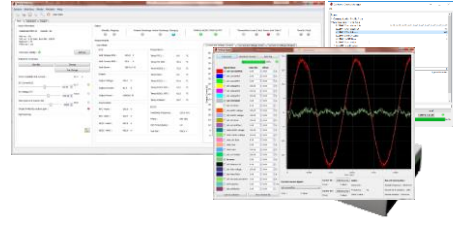
<p><u>WA009 – USB to CAN transceiver (Kvaser)</u> Compatible with BMPU Monitor</p>	
<p><u>WA021 – BMPU monitor license (USB license dongle)</u> A Windows based GUI (Graphical User Interface) for easy access to measurements, monitoring and configuration parameters. It can be used to control BMPU-R2 as a PC based master or to speed-up integration of a dedicated system master.</p> <p>See BMPU-R2 GUI user guide for more details.</p>	

10.3. Related products

EVI is a dual standard Supply Equipment Communication Controller (SECC) with all required signals for CCS2 /Combo and CHAdeMO communications.

Main features:

- CCS protocol compatible
 - ISO15118-2 and ISO15118-20
- CHAdeMO compatible (via Extension board)
 - Version 0.9 & 1.2
- Insulation Measurement Device according to IEC61557-8
- High voltage 920V charging.
- OCPP 1.6 and soon OCPP 2.0.1
- Smart Charging & V2G charging modes
- Cable temperature measurement
- Crypto ready with Secure Element embedded



EVIX – EVI Extension board:

An optional extension board (EVIX) can add additional functions such as:

- EVIX-AD6: Addressing of 6 power units
- EVIX-AD14: Addressing of 14 power units
- EVIX-AD6-CHA: CHAdeMO HW interface & Addressing 6 power units
- EVIX-IO: Peripheral extension board

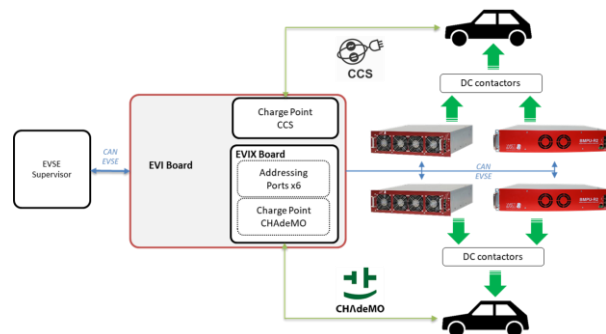

Figure 34: EVI & EVIX integration on EVSE environment

Other customization options available under request

contact@wattandwell.com

+33 1 75 5 11 50